



Hardware and Engineering

PS4-201-MM1

04/99 AWB 27-1184 GB

1st published 1994, edition 04/94

2nd published 1995, edition 04/94

3rd published 1997, edition 06/97

4th published 1999, edition 04/99

See modifications list on page II

© Moeller GmbH, Bonn

Author: Werner Albrecht

Editor: Thomas Kracht

Translator: Terence Osborn



Caution!

Dangerous electrical voltage!

Before commencing the installation

- Disconnect the power supply of the device.
- Ensure that the device cannot be accidentally restarted.
- Verify isolation from the supply.
- Earth and short circuit.
- Cover or enclose neighbouring units that are live.
- Follow the engineering instructions (AWA) of the device concerned.
- Only suitably qualified personnel may work on this device/system.
- Before installation and before touching the device ensure that you are free of electrostatic charge.
- Connecting cables and signal lines should be installed so that inductive or capacitive interference do not impair the automation functions.
- Install automation devices and related operating elements in such a way that they are well protected against unintentional operation.
- Suitable safety hardware and software measures should be implemented for the I/O interface so that a line or wire breakage on the signal side does not result in undefined states in the automation devices.
- Ensure a reliable electrical isolation of the low voltage for the 24 volt supply. Only use power supply units complying with IEC 60 364-4-41 or HD 384.4.41 S2.
- Deviations of the mains voltage from the rated value must not exceed the tolerance limits given in the specifications, otherwise this may cause malfunction and dangerous operation.
- Emergency stop devices complying with IEC/EN 60 204-1 must be effective in all operating modes of the automation devices. Unlatching the emergency-stop devices must not cause uncontrolled operation or restart.
- Devices that are designed for mounting in housings or control cabinets must only be operated and controlled after they have been installed with the housing closed. Desktop or portable units must only be operated and controlled in enclosed housings.
- Measures should be taken to ensure the proper restart of programs interrupted after a voltage dip or failure. This should not cause dangerous operating states even for a short time. If necessary, emergency-stop devices should be implemented.

IBM is a registered trademark of International Business Machines Corporation.

All other brand and product names are trademarks or registered trademarks of the owner concerned.

All rights reserved, including those of the translation.

No part of this manual may be reproduced in any form (printed, photocopy, microfilm or any other process) or processed, duplicated or distributed by means of electronic systems without written permission of Moeller GmbH, Bonn.

Subject to alterations without notice.

List of revisions to AWB 27-1184 GB

Edition date	Page	Description	New	Modification	Omitted
04/99	gen.	Sucosoft S 30-S4			×
		Sucosoft S 4 → S 40		×	
		AWB 27-1185/1186			×
		AWB 27-1280-D → AWB 2700-1305 D		×	
		AWB 27-1281-D → AWB 2700-1306 D		×	
	14	Legend ③	×		
	41	Slave adress		×	
	52	Note	×		
	52/53	Grafic/Table		×	
	83	EMV: RFI, Surge		×	

Contents

About this Manual	5
Documentation for the PS4-200	5
Symbols	6
1 About the PS4-200 Compact PLC	7
Hardware and software requirements	7
Features	8
Setup	8
Elements	10
2 Engineering	17
Electromagnetic compatibility (EMC)	17
Connections	17
Programming device interface	20
Suconet K interface	22
Setting the bus terminating resistors	23
Local expansion	23
Arrangement of the control cabinet	24
Power supply	25
Avoiding interference	30
3 Mounting	35
Mounting on a top-hat rail	35
Mounting on feet	36
4 Software Configuration	37
General	37
Topology configuration procedure	38
Configuring and setting parameters	40
Configuration example with local expansions	45
Configuration example	46
5 Slave Addressing	51
Slaves for expanding remote inputs/outputs	51
Intelligent slaves	53

6 Operation	57
Power-up behaviour	57
Shut-down behaviour	57
Operating states of the PLC	58
Start-up behaviour	61
Program transfer	63
Starting the PLC with a program stored in the memory module	65
Programming via Suconet K	65
7 Testing/Commissioning/Diagnostics	67
Status LEDs	67
Diagnostics	68
Message byte	71
Appendix	73
Optimizing the exchange of send and receive data	73
Accessories	77
Slave addressing	78
Technical Data	81
Index	87

About this Manual

Documentation for the PS4-200

The documentation for the PS4-201-MM1 compact PLC (referred to below as PS4-200) is subdivided into four manuals with the following topics:

Hardware and engineering

User interface for the programming software

Programming

Training guide

Hardware and engineering manual

This manual, “Hardware and Engineering”, explains how the PLCs are to be installed and engineered. It describes the elements of the PS4-200 and tells you how to alter the settings.

The configuration and setting of PLC parameters is carried out in the topology configurator of the programming software. This is described in the chapter “Software configuration”.

The chapter “Slave addressing” defines the general syntax rules for addressing the stations in a Suconet K network.

The chapter “Test/commissioning/diagnostics” provides an overview of the possible error and diagnostic signals and their meanings.

Manual for user interface for the programming software

To program the PS4-200 you need the Sucosoft S 40 programming software (Windows, IEC 1131).

The user interface for the software is described in the manual AWB2700-1305GB.

Programming manual

Information on programming the PS4-200 is contained in the “Language elements of the PS4-150/-200/-300 and PS416” manual (AWB2700-1306GB).

Training guide

The training guide AWB27-1307GB uses practical examples to illustrate the key functions of the SucoSoft S 40 software.

Symbols

The symbols in this manual have the following meaning:



Draws your attention to interesting tips and additional information



Warning!

Warns of the possibility of damage. The product, anything in the immediate vicinity and data may be damaged.



Caution!

Warns of the possibility of severe damage. The product, anything in the immediate vicinity and data may be severely damaged or totally destroyed. There is also a risk of injury or even death.

► Indicates handling instructions

1 About the PS4-200 Compact PLC

Hardware and software requirements

Sucosoft S 40

To program the PS4-200 you need a PC (IBM or IBM-compatible) with

at least a Pentium processor

a Windows 95, Windows 98 or Windows NT 4.0¹⁾ operating system

at least 16 Mbyte RAM

3.5"disk drive/1.44 MByte and CD-ROM drive

Hard disk with at least 40 MByte free capacity; the temporary directory C:\{_S40_}.TMP is created during the installation and deleted again. This requires at least 250 Kbytes free space on drive C:

Serial ports (COM 1 to COM 4)

Parallel printer port (LPT1)

VGA graphics card

Programming cable ZB4-303-KB1 (connecting cable between PC and PS4-200)

- 1) (Sucosoft 3.x is the last version supported by Windows 3.1x)

Features

The main features of the PS4-200 compact PLC are as follows:

- 24 V DC power supply
- 8 digital inputs, 2 4V DC
- 6 digital outputs, 24 V DC
- 2 analog inputs
- 1 analog output

Setup

Figure 1 provides an overview of the operating and display elements of the programmable controller as well as the device connections.



Warning!

Make sure that you are free of electrostatic charge before touching the PLCs, in order to protect the components from static electrical discharges.

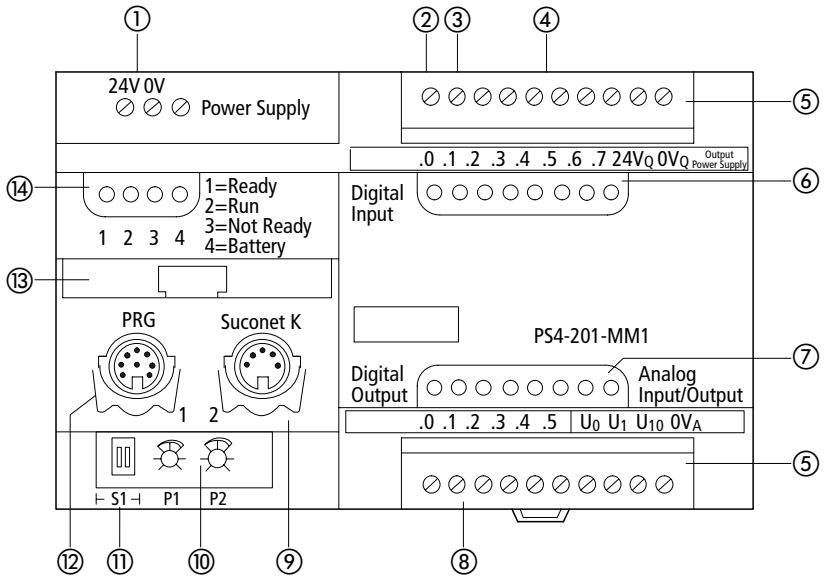

Figure 1: Overview of the PS4-200

- ① 24 V DC power supply
- ② High-speed counter input (alternative to I 0.0), 3 kHz
- ③ Alarm input (alternative to I 0.1)
- ④ 8 digital inputs 24 V DC and 24 V DC input for the outputs
- ⑤ Plug-in screw terminal
- ⑥ Status LEDs for digital inputs
- ⑦ Status LEDs for digital outputs
- ⑧ 6 digital outputs 24 V DC/0.5 A; short-circuit and overload proof
2 analog inputs U_0 , U_1 (0 to 10 V)
1 analog output U_{10} (0 to 10 V)
- ⑨ Suconet K interface
- ⑩ Setpoint potentiometers P1, P2
- ⑪ Switch S1 for bus terminating resistors
- ⑫ Programming device interface (PRG)
- ⑬ Memory module
- ⑭ Status LEDs for the PLC

Elements

① Power supply unit

The PS4-200 is operated with a rated voltage of 24 V DC. The power supply connection is protected against polarity reversal. The 24 V connection enables the PLC in the control cabinet to be supplied with voltages to industrial standards (IEC).

② High-speed counter input

You can count pulses at up to 3 kHz via the digital input I 0.0, irrespective of the cycle time. The up counter is capable of processing square-wave pulses with a pulse/pause ratio of 1. A function block is provided in the programming software for the high-speed counter.

③ Alarm input

The digital input I 0.1 enables you to respond to events quickly, irrespective of the cycle time. You can use either the rising or the falling edge to evaluate these events. A function block is provided in the programming software for the alarm input.

④ Digital inputs

The PLC has 8 digital inputs. They are galvanically isolated from the CPU. The inputs are designed for 24 V DC. The input delay of normally 55 ms ensures short response times (e.g. for direct peripheral scans and alarm evaluations). Inputs I 0.0 to I 0.7 can be addressed in bit or byte format with peripheral I/O commands.

⑥ Status LEDs for digital inputs

The physical states of the inputs and the diagnostics status word are indicated by LEDs.

⑦ Status LEDs for outputs

The logical states of the outputs are indicated with light-emitting diodes (LEDs). Outputs Q 0.6 and Q 0.7 are only provided as LEDs.

⑧ Digital/analog outputs, analog inputs

Digital outputs:

The PS4-200 has 6 24 V/0.5 A digital outputs. They are galvanically isolated from the CPU and protected against short-circuits and overloads. Up to four outputs can be connected in parallel.



Outputs Q 0.0 to Q 0.5 can be addressed either in bit or byte format with peripheral commands (see chapter 5 “Slave addressing”).

Analog inputs/outputs:

The controller has two analog inputs and one analog output. The signal range is 0 to 10 V. The resolution of the inputs is 10 bits (1024 increments), while that of the output is 12 bits (4096 increments)..



The section “Power supply” in the Engineering chapter contains a connection diagram of the analog inputs and outputs.

All the inputs and outputs are wired via plug-in screw terminals.

⑨ **Suconet K interface**

The RS 485 interface is galvanically isolated from the CPU. It has the following functions:

Networking of Suconet K stations (e.g. EM4... expansion modules)

Data exchange with partner devices that have a serial port (printers, terminals, etc.). This communication interface is used for process data acquisition, visualization, etc. Data for process control must not be exchanged here.

Programming networks for several PLCs via a PC (see section “Programming with Suconet K” in the “Operation” chapter).

⑩ **Setpoint potentiometers**

You can set the two setpoint potentiometers P1 and P2 externally, in other words direct adjustment without the need for a programming device. The resolution is 10 bits (1024 increments). They can be accessed with the operands “IAW0” and “IAW2”.

⑪ **Switch S1 for bus terminating resistors**

You can set the bus terminating resistors for the first and last physical stations with switch S1.

⑫ Programming device interface (PRG)

The RS 232 interface is galvanically isolated from the CPU. It has the following functions:

Programming the PLC via the PC

Data exchange with partner devices that have a serial port (printers, terminals, etc.). This type of communication is used for process data acquisition, visualization etc. but should not be used to exchange data for process control (see also “Function block SCO” in the manual “Language Elements of the PS4-150/-200/-300 and PS416” in AWB2700-1306GB, chapter 6).

⑬ Memory modules

The PS4-200 has an internal, battery-backed, 32 kByte RAM. The memory is subdivided into a data memory and a user program memory.

Up to 24 Kbyte are available for the user program. This allocation is dynamic, i.e. if the data memory requires more than 8 Kbyte, the size of the user program memory is reduced accordingly.

The memory capacity of the internal RAM can be expanded with plug-in memory modules. The available modules are as follows:

The 32 Kbyte RAM module expands the user program memory. Up to 56 Kbyte can then be allocated to this memory.

The 128 Kbyte flash module is subdivided into a 64 Kbyte backup memory (retentive storage of the user program in the event of a voltage failure) and a 64 Kbyte memory for recipe data, for example.

The 160 Kbyte combination module integrates all the features of the other two memory modules.

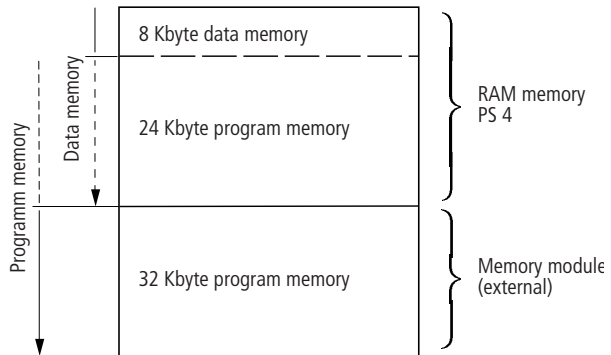

Figure 2: Dynamic memory allocation

⑭ Status LEDs for the PLC

The PLC states are indicated by means of the “Ready”, “Run”, “Not Ready” and “Battery” LEDs (see chapter entitled “Test/Commissioning/Diagnostics”).

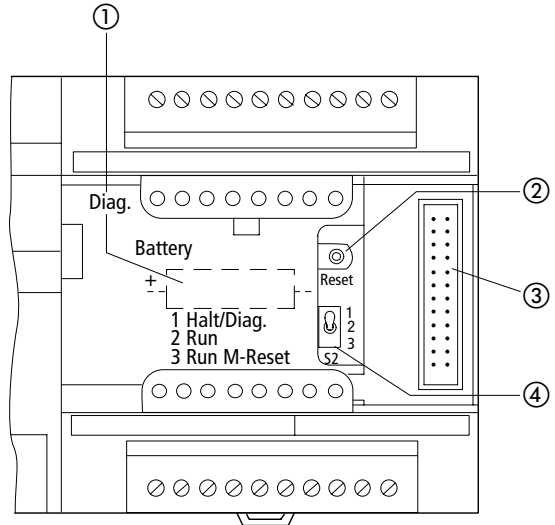

Figure 3: Controls and display elements of the PS4-200 (with housing flap open)

- ① Back-up battery
- ② Reset button
- ③ Plug connector for local expansion modules
- ④ Operating mode selector switch

① **Back-up battery**

The battery backs up the internal RAM and the real-time clock.



Warning!

The back-up battery must only be replaced with the power supply switched on, or data will be lost.

**②, ④ Operating mode selector switch/
reset button**

You can select the “Halt” (stop), “Run” and “Run M-Reset” modes with the operating mode selector switch. The selected mode is activated when you press the Reset button. The operating states are described in detail in the chapter “Operation”.

③ Plug connector for local expansion module

The plug connector provides the interface for connecting the LE4-... local expansion modules

Real-time clock

The PLC is equipped with a battery-backed, real-time clock. It facilitates the time-controlled switching of machines and equipment. You can change between summer and winter time in the user program. A function block in the user program can be used to address and scan the real-time clock.

2 Engineering

Electromagnetic compatibility (EMC)

Observe the engineering instructions in the manual “EMC Engineering Guidelines for Automation Systems” (AWB27-1287GB).

Connections

Screened data and signal cables

- ▶ Route screened data and signal cables on the left and the right of the device along the shortest possible distance and connect the screen braid to the ground terminal using a low-impedance connection and large contact areas (See Fig. 4, item ①).
- ▶ Connect the screen braid with the metal sleeve of the plug connector (DIN plugs) ③.
- ▶ Insulate the end of the screen braid as close as possible to the signal cable entry ②.

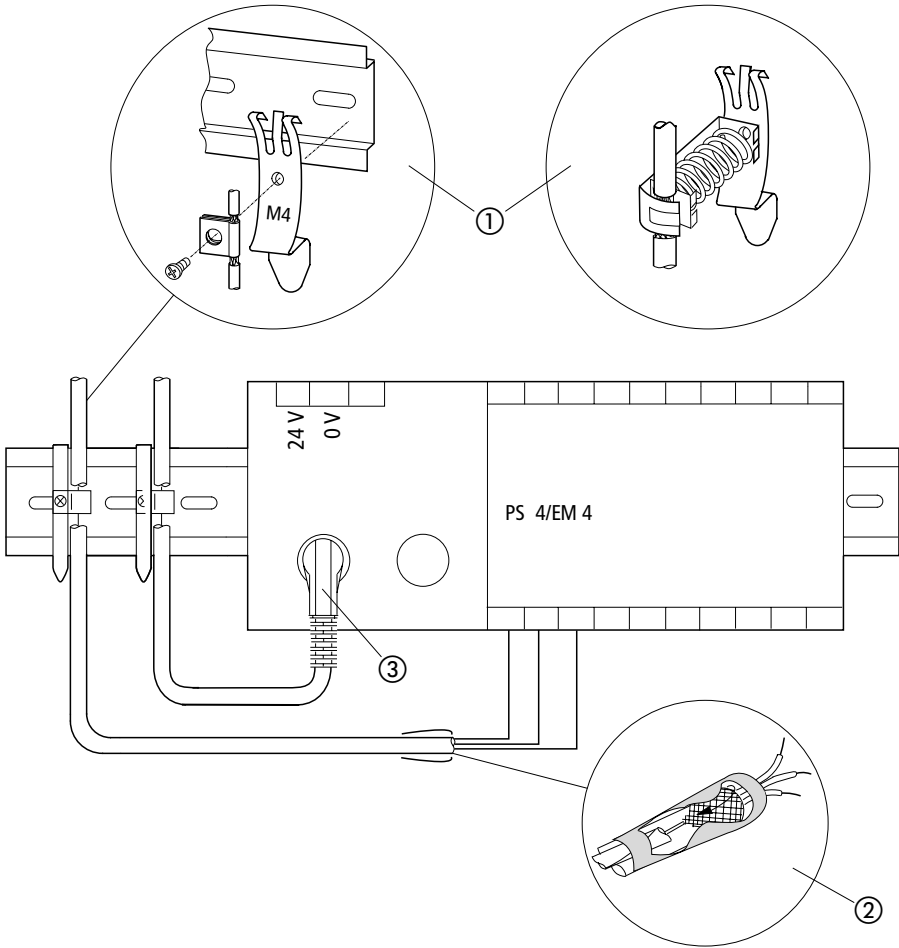

Figure 4: Screen connection to reference potential surface

Overview

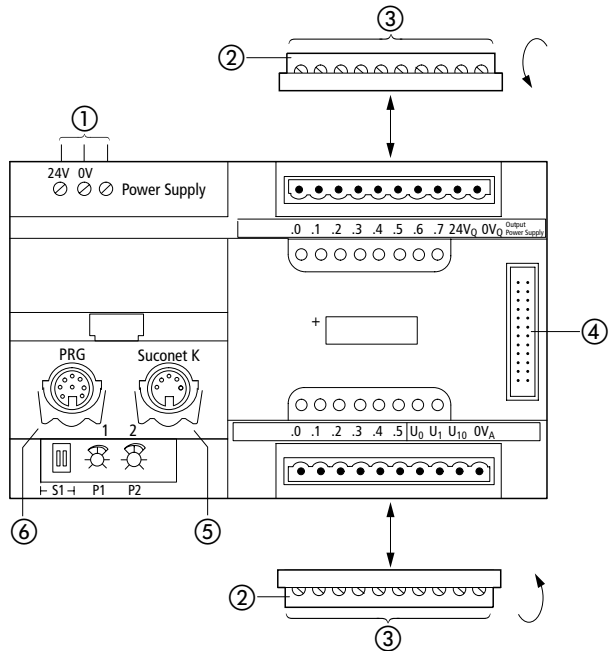

Figure 5: Overview of connections

- ① Screw terminals: 24 V DC power supply
Terminal cross-sections:
Flexible with ferrule 0.22 - 2.5 mm²
Solid 0.22 - 2.5 mm²
- ② Plug-in screw terminal
- ③ Terminal cross-sections:
Flexible with ferrule 0.22 to 1.5 mm²
Solid 0.22 to 2.5 mm²
- ④ Plug connector for local expansion modules (LE4)
- ⑤ Suconet K interface (RS 485)
- ⑥ Interface for programming device (RS 232)

Programming device interface

Connector pin assignments

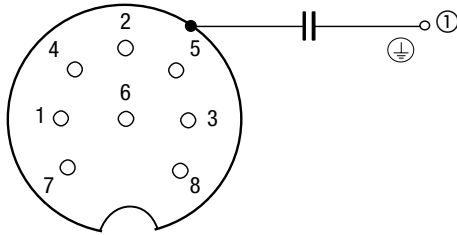

Figure 6: Pin assignment of the programming device connector (PRG) (left-hand socket, top view)

- ① The housing of the socket is connected to the ground terminal of the power supply for the PS4-200 via a capacitor (only applies to version 03 and earlier).

PIN 1	Not assigned
PIN 2	RxD
PIN 3	0 V of interface
PIN 4	Not assigned
PIN 5	TxD
PIN 6 – 8	Not assigned

Connecting the programming device (PC)

- ▶ Connect the PC to the PRG interface of the PS4-200 (left-hand socket) using the programming cable ZB4-303-KB1.

PS4-201-MM1:
PRG interface
(8-pole. DIN pin
connector)

PC:
COM interface
(9-pole. socket)

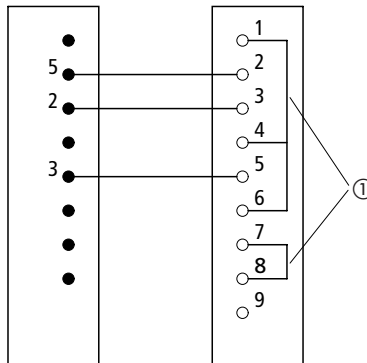

Figure 7: Pin assignment of the ZB4-303-KB1 programming cable

① Jumpers



Warning!

In order to avoid potential equalization currents between the PLC and the PC, devices attached to the PRG and Suconet K interfaces must have the same ground potential. If the ground potentials differ, the interfaces can be destroyed.

If identical ground potentials cannot be achieved, either connect the PC to the mains supply via an isolating transformer or use a laptop powered by an internal battery.

Suconet K interface

Connector pin assignments

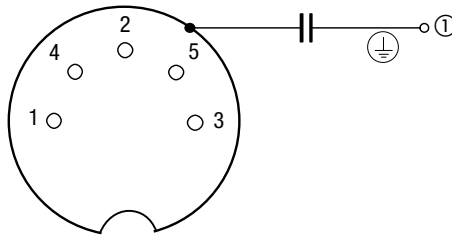

Figure 8: Pin assignment of the Suconet K interface (PRG) (right-hand socket, top view)

- ① The housing of the socket is connected to the ground terminal of the PS4-200 power supply via a capacitor (only applies to version 03 and earlier).

PIN 1	RS 485 data cable, Suconet K (TB/RB)
PIN 2	Assigned internally
PIN 3	Assigned internally
PIN 4	RS 485 data cable, Suconet K (TA/RA)
PIN 5	Assigned internally

Connecting to the Suconet K field bus

- ▶ Use the bus cable KPG 1-PS3 to connect additional Suconet K stations (PS4, EM4) to the compact PLC.



- ▶ Connect the screen of the Suconet K data cable both to the potential reference surface and to the housing of the plug connector (see Fig. 4 “Screen connection to reference potential surface”).

Setting the bus terminating resistors

- ▶ Set the bus terminating resistors on the module for the first and last physical stations on a line. To do this, both S1 switches should be set to the “ON” position. Both switches must be set to the “OFF” position for all other stations.

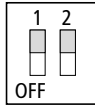

Figure 9: Bus terminating resistors active



In order for the PLC to function correctly the two S1 switches must be set to the same position (“ON” or “OFF”).

Local expansion

The PS4-200 can be expanded locally. The local expansion modules (LE4 modules) are connected to the local bus connector of the PS4-200 using a local bus ribbon cable. Up to six LEs can be connected locally. All available LE types can be used. Up to two of the LE4 shown in the legend under ① can be connected to a local line. They must only be connected directly adjacent to the master (from version 05).



- ① LE4-206-AA1, LE4-622-CX1, LE4-501-BS1, LE4-503-BS1, LE4-505-BS1

Arrangement of the control cabinet

The arrangement of the components in the control cabinet has a significant influence on the correct operation of the machine or plant. When planning, designing and installing the equipment, ensure that the power section and the control section are separated from one another. The power section includes:

- Contactors
- Coupling modules
- Transformers
- Frequency converters
- Power converters
- DC power supply units

In order to effectively eliminate electromagnetic interference, we recommend subdividing the control cabinet into sections according to the different power and interference levels. Simple partitions are often sufficient to reduce interference in small control cabinets.

Ventilation

In order to ensure that the PS4-200 is adequately cooled, a minimum clearance of 5 cm (2") must be allowed between other components and the ventilation slots in the housing. The values specified in the technical data must be observed (see Appendix).

Device arrangement

The PS4-200 should be installed horizontally in the control cabinet as shown in the following figure.

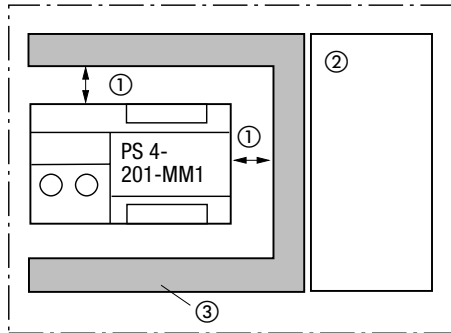

Figure 10: Horizontal installation

- ① At least 5 cm (2") clearance
- ② Power section
- ③ Cable duct



When you use the PS4-200 together with local expansion modules, you must install the controller horizontally.

Power supply

The next few pages show circuit diagrams for the following power supply arrangements:

Figure 11:

Common power supply for the PS4-200 and the digital inputs/outputs wired for grounded operation

Figure 12:

Common power supply for the PS4-200 and the digital inputs/outputs wired for non-grounded (floating ground) operation



An insulation monitoring device must be installed if the supply voltage is not grounded (EN 60204, Part 1 and VDE 0100, Part 725). For floating operation, the 24 V DC power supply must be a safety extra-low voltage version to IEC 364-4-41.

Legend for Figure 11:

- ① Main switch
- ② Protective device for power supply units
- ③ Miniature circuit-breakers
- ④ Power supply for the digital inputs
- ⑤ Link (no longer required from PS4-200 version 04)
- ⑥ Power supply for the PS4-200
- ⑦ Power supply for the digital outputs
- ⑧ Reference potential for the digital inputs/outputs
- ⑨ Terminal with PE connection
(no longer required from version 04)
- ⑩ Connect top-hat rail to mounting plate (galvanized sheet steel) with a low impedance connection over a large surface and with protection against corrosion.



Maintain a clearance of at least 30 cm (12") between the analog cable and the power supply cables.

Do not lay the 0 V of the analog signals together with the 0 V of the PS4-200 and the 0 V of the digital inputs/outputs.

Ensure that the analog actuators and transmitters are galvanically isolated. If potential isolation is not sufficient, the manufacturers of the analog transmitters and actuators can provide suitable filters.

Power supply

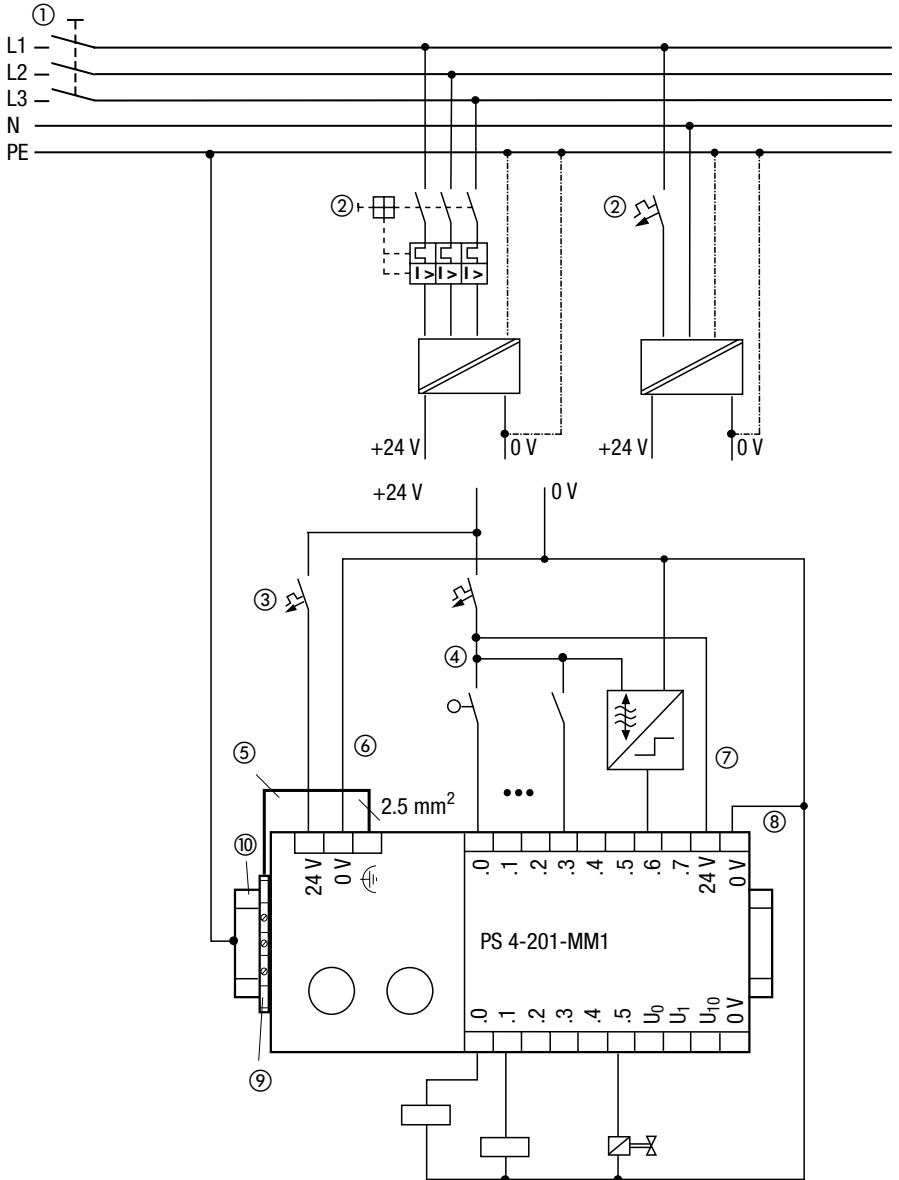

Figure 11: Common power supply wired for grounded operation

Legend for Figure 12:

- ① Main switch
- ② Protective device for power supply units
- ③ Capacitive ground
- ④ Potential equalization rail
- ⑤ Earth fault monitoring device
- ⑥ Miniature circuit-breaker
- ⑦ Power supply for the digital inputs
- ⑧ Link (no longer required from PS4-200 version 04)
- ⑨ Power supply for the PS4-200
- ⑩ Power supply for the digital outputs
- ⑪ Reference potential for the digital inputs/outputs
- ⑫ Terminal with PE connection
(no longer required from version 04)
- ⑬ Connect top-hat rail to mounting plate (galvanized sheet steel) with a low impedance connection over a large surface and with protection against corrosion.



Maintain a clearance of at least 30 cm (12") between the analog cable and the power supply cables.

Do not lay the 0 V of the analog signals together with the 0 V of the PS4-200 and the 0 V of the digital inputs/outputs.

Ensure that the analog actuators and transmitters are galvanically isolated. If potential isolation is not sufficient, the manufacturers of the analog transmitters and actuators can provide suitable filters.

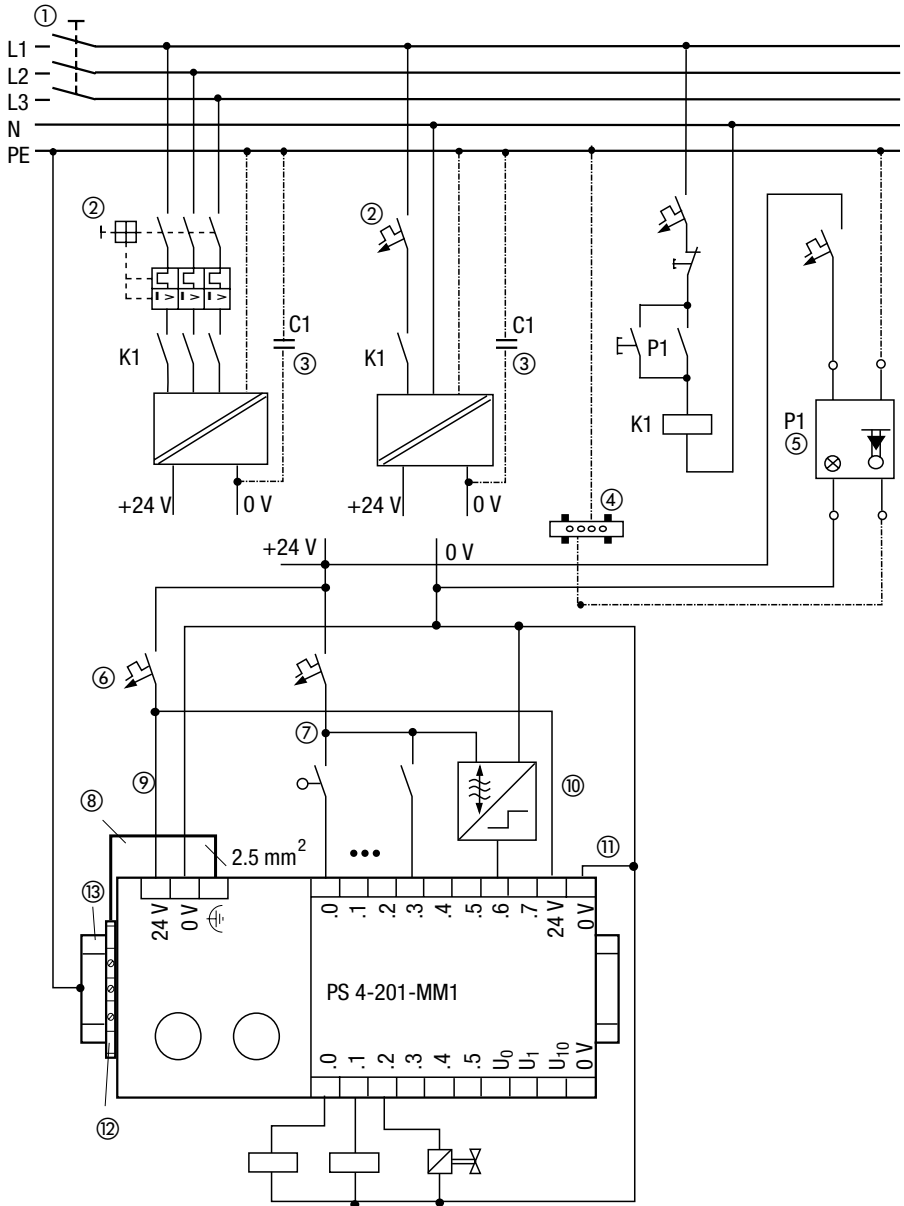

Figure 12: Common power supply wired for non-grounded operation

Avoiding interference

Cabling and wiring

Cables come under the following categories:

Power cables (e.g. cables carrying heavy current or cables to power converters, contactors or solenoid valves)

Control and signal cables
(e.g. digital input cables)

Measuring and signal cables (e.g. field bus cables)



Power, control and signal cables must always be laid as far apart from one another as possible, in order to prevent capacitive and inductive interference. If separate cabling is not possible, the cables that represent the potential source of interference must be screened above all.

In order to keep interference to a minimum ensure that the cabling both inside and outside the control cabinet is laid correctly as follows:

- ▶ Avoid long, parallel cable runs with adjacent cables of different power ratings.
- ▶ Always lay AC cables separately from DC cables.

Observe the following minimum clearances:

At least 10 cm (4") between power cables and signal cables.

At least 30 cm (12") between power cables and data/analog cables.

- ▶ Make sure that the supply and return cables belonging to each circuit are laid together. The opposing direction of current flow means that the sum of all the currents is zero so that any fields which are produced are compensated.

- ① Cover
- ② Communication cables
- ③ Cable duct
- ④ Measuring cables, analog cables
- ⑤ Control cables
- ⑥ Power cables
- ⑦ Continuous partition

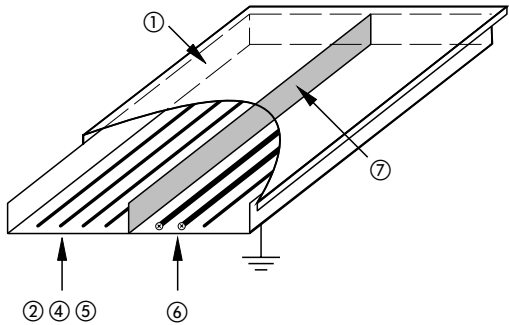
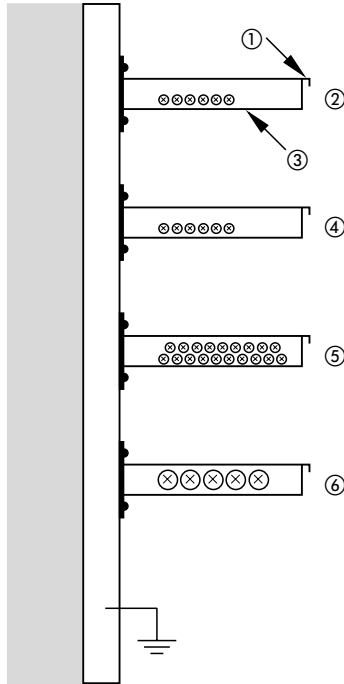

Figure 13: Using separate ducts for power and signal cables

Suppressor circuits for interference sources

- ▶ All suppressor circuits must be installed as close as possible to the interference sources (contactors, relays, valves).



Suppressor circuits should be provided for all switched inductances.

Screening

- ▶ Only use screened cables for the programming device interface (PRG) and the Suconet K interface of the PS4-200.

General rule: the lower the coupling impedance, the better the screening effect. The screen is then able to carry high interference currents.



If you use the Suconet K or PRG interface, connect the screen of the cable to the housing of the plug connector. The housing of the socket is connected via a capacitor to the earth terminal of the power supply.

Lightning protection

External lightning protection

All cables which are laid between two different buildings must be screened. Metal conduits are recommended for this purpose. Protective elements against overvoltage, such as varistors or other types of lightning arrester, should be used for signal cables. The cables must be protected at the point at which they enter the building, or at the latest at the control cabinet.

Internal lightning protection

Internal lightning protection includes all measures that reduce the effects of the lightning current and its electrical and magnetic fields on the metal installations and electrical systems inside a building. These measures comprise:

- Lightning-protection potential equalization
- Screening
- Overvoltage protection devices

Further information on this subject is provided in the TB27-001GB manual from Moeller entitled “Electromagnetic Compatibility (EMC) of Automation Systems”.

3 Mounting

Mounting on a top-hat rail

Proceed as follows to mount the PLC on a top-hat rail:

- ▶ Place the module on the top-hat rail so that the top edge of the rail latches into the groove.
- ▶ Insert a screwdriver ① into the slot of the sliding clip and lever the clip down ②.
- ▶ Press the module onto the top-hat rail ③.
- ▶ Release the sliding clip. It will then snap into position behind the top-hat rail.
- ▶ Check that the module is seated firmly.

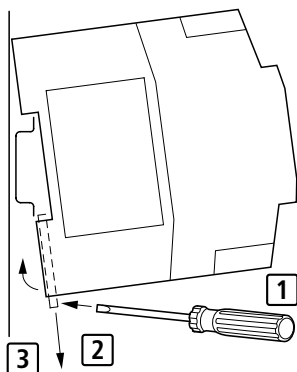

Figure 14: Mounting on a top-hat rail

Mounting on feet

Proceed as follows to mount the PLC on feet:

- ▶ Press in the feet so that they snap into position ①.
- ▶ Check that they are correctly in position. The lug must latch in the hole ②.
- ▶ Fasten the feet to the mounting plate ③ with M4 screws.

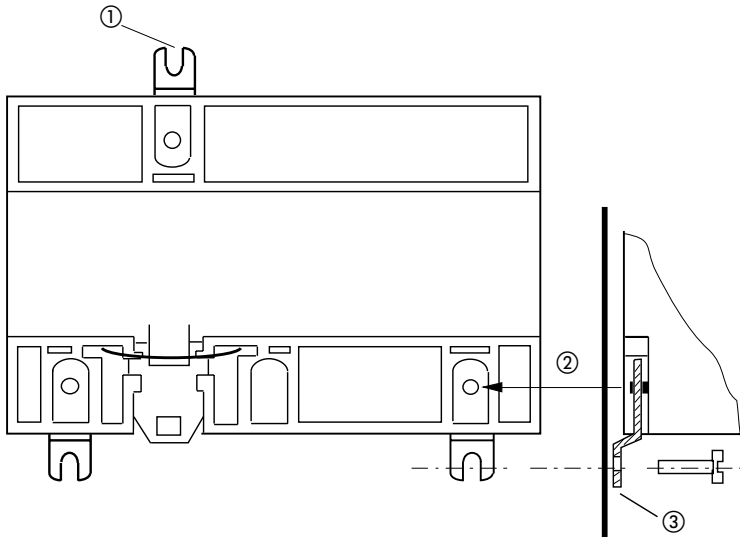

Figure 15: Mounting on feet

4 Software Configuration

General

You can configure the PLCs and all the other components you need for your application with the SucoSoft S 40 Topology Configurator. These components are as follows:

Master PLC (with local expansion modules for the inputs/outputs)

Network stations (slaves for expanding the remote I/O or intelligent slaves)

Local expansion modules (LE4-...)

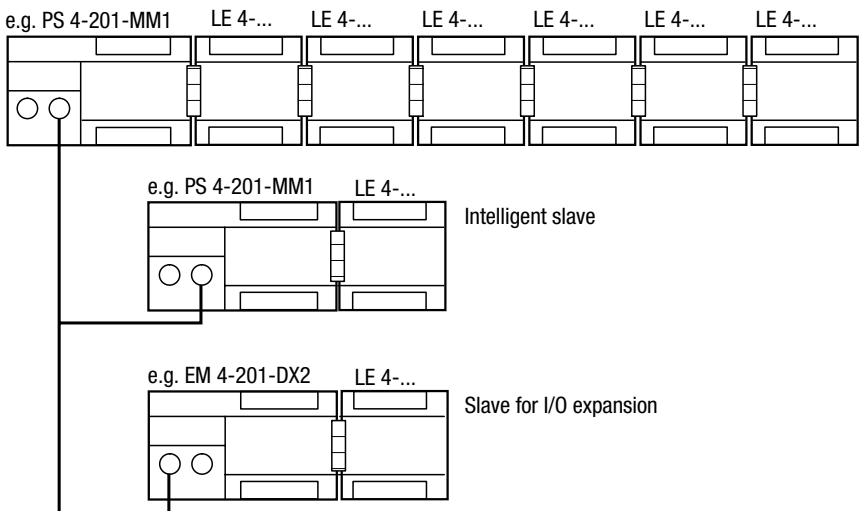

Figure 16: Components of a topology configuration



The following example describes the procedure for configuring a topology.

Topology configuration procedure

Each Suconet K line in an automation system is assigned to a single master. All the other stations on the master's line are slaves. A separate configuration must be defined for every station with its own CPU, i.e. for the master itself and for all intelligent slaves.

Configuration of the master with local expansion modules

The master's configuration also specifies the local expansion modules. Local expansion modules are assigned the same line number and station number as the master ("0" for both line and station number). The modules are numbered consecutively. The master is module number "0" and the local expansion modules are numbered "1" to "6".

Configuration of the master with remote expansion modules

The master's configuration also specifies the slaves that are connected to the master's line. The slaves are classified according to whether they have their own CPU (intelligent slaves) or not (slaves for expanding the remote inputs/outputs):

In the case of **intelligent slaves** (e.g. PS4-200) the master configuration only specifies the device itself, and not any local expansion modules (LE4...) that are connected to it.

In the case of **slaves for expanding the remote inputs/outputs** the connected local expansion modules (modules 1 to 6) are specified in the master's configuration file as "network stations" in addition to the base module (module 0).

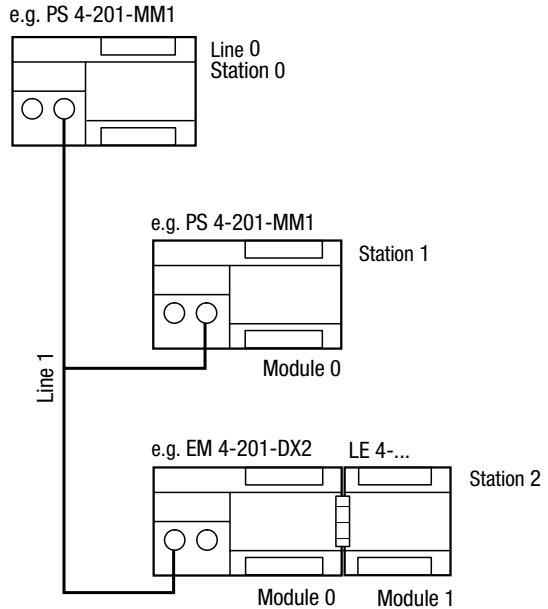

Figure 17: Master configuration



If intelligent Suconet K stations have local expansion modules, you only specify the base module (module 0) as a “network station” in the master’s configuration. The local expansion modules are specified in the intelligent slave’s configuration but not in the master’s configuration.

Configuration of intelligent slaves

All the local components of intelligent slaves are configured in the slave’s configuration file. Their line and station numbers are always 0. The modules are numbered consecutively.

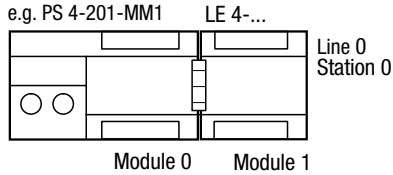

Figure 18: Slave configuration

Configuration of slaves for expanding the remote inputs/outputs

Slaves for expanding the remote inputs/outputs are configured in the master's configuration file.

Configuring and setting parameters

The configuration steps for the PS4-200 PLCs described here differ according to the functions the stations must perform:

- Master
- Intelligent slave
- SCO (from PLC firmware version 05)



“SCO” stands for serial communication. This function allows the PS4-200 to exchange serial data with a partner device via its Suconet K interface (see also “Function block SCO” in the manual “Language Elements of the PS4-150/-200/-300 and PS416” in AWB2700-1306GB, chapter 6).

The table below shows how the various types of station can be configured depending on their functions. The fields which are not self-explanatory are subsequently described in more detail.

Table 1: Station configurations

	Master	Intelligent slave		SCO (from ver. 05)
		(m)	(s)	
Line	0	1	0	–
Station	0	1 to 8	0	–
Module	0	0	0	–

(m) = Master's configuration (s)=Slave's configuration

Table 2: Station parameters

	Master	Intelligent slave		SCO (from ver. 05)
		(m)	(s)	
Bus status	Master	–	Slave	SCO
Baud rate (kBaud)	187./375	–	–	0.3 to 19.2
Protocol	Suconet K/K1 (K1: 187.5 kBaud only)	–	–	Start bit Stop bit Data bit Parity
Slave address	–	–	2 to 9	–
CRC	Optional for slaves	Optional via master	–	–
Input data (Receive data)	–	a	c	–
Output data (Send data)	–	b	d	–
Remote control	–	–	Optional	–

a-d = See description of input/output data in the table below

- Line: Number of the network line to which a station is connected. The master is always connected to line 0 and the slaves to line 1.
- Station: Number of the station connected to a line
- Module: Number of the module belonging to a station
- Baud rate: Select 375 kBaud as the data transfer rate if only Suconet K stations are connected to the Suconet K line. The internal plausibility checks of Sucosoft S 40 will automatically set the baud rate of the line to 187.5 kBaud if the line includes Suconet K1 stations.
- Protocol: The following baud rates are available for serial communication via the SCO function block: 300, 600, 1200, 2400, 4800, 9600, 19200 baud.
- The following interface parameters can be defined for serial data exchange with a partner device via the Suconet K interface. These settings must be identical to those on the partner device.

Table 3: Interface parameter settings for serial communication via the RS 485 interface

Start bit	Stop bit	Data bit	Parity
1	1	8	–
1	1	8	even
1	1	8	odd
1	2	8	–

- Slave address:** The station number must be entered here in order to configure an intelligent slave. The station address is always 1 higher than the station number (e.g. slave 1 has address 2).
- CRC:** Method of enhancing data transmission integrity. You should activate CRC (ON) if you attach greater importance to data integrity than to short response times.
- Remote Control:** If this parameter is active (ON), the intelligent slave always has the same status as the master. If the master changes from the “Halt” (stop) state to the “Run” state, for example, or vice versa, the intelligent slave changes its state accordingly. However, the operating mode selector switch of the intelligent slave must not be set to “Halt” (stop).
- Input data, master (a):** Number of bytes which the master must receive from the intelligent slave. This number must be identical to the number of output bytes (d) defined in the configuration of the intelligent slave.
- Output data, master (b):** Number of bytes which the master must send to the intelligent slave. This number must be identical to the number of input bytes (c) defined in the configuration of the intelligent slave.
- Input data, slave (c):** Number of bytes which the intelligent slave must receive from the master. This number must be identical to the number of output bytes (b) defined in the configuration of the master.
- Output data, slave (d):** Number of bytes which the intelligent slave must send to the master. This number must be identical to the number of input bytes (a) defined in the configuration of the master.

Maximum values for send and receive bytes

The Suconet K protocol allows data with a variable length to be transferred cyclically, whereby the number of bytes is dependent on the settings for the master and the slave (see below). The data length for communication with slaves for expanding the remote inputs/outputs is dependent on the slave type. With intelligent slaves you can specify the number of send and receive bytes yourself. However, the following maximum values must not be exceeded:

Table 4: Maximum values for send and receive bytes for the PS4-200

Send/receive bytes	Master	Slave
Max. no. of send bytes (output)	128	78
Max. no. of receive bytes (input)	128	78
Max. no. of send and receive bytes (output/input)	128*	78

* For certain configurations, the number of send and receive bytes can be increased to 256 (see Appendix).



The maximum number of receive bytes (input bytes) also includes the diagnostics bytes of the stations and of any local expansion modules which are connected to the same line.

Defining input and output data

- ▶ First of all you must decide how many bytes an intelligent slave should send to the master and specify this number with the “Input data” parameter in the master’s configuration. When you later specify the slave’s own configuration, you must specify the same number with the “Output data” parameter.
- ▶ Now decide how many bytes the master is to send to the intelligent slave and specify this number as the “Output data” parameter in the master’s configuration. When you later define the slave’s own configuration, you must specify the same number with the “Input data” parameter.

Configuration example with local expansions

Table 5: Configuration with local expansion modules

Type	Line	Station	Module	Parameter
PS4-200	0	0	0	Bus status: master
1st LE4	0	0	1	–
2nd LE4	0	0	2	–
3rd LE4	0	0	3	–
4th LE4	0	0	4	–
5th LE4	0	0	5	–
6th LE4	0	0	6	–

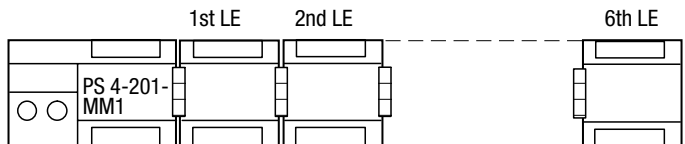

Configuration example

This example requires topology configurations for the master (device A) and the intelligent slaves (devices B and C).



Note that intelligent slaves are configured twice - once in the master's configuration and once in the slave's own configuration.

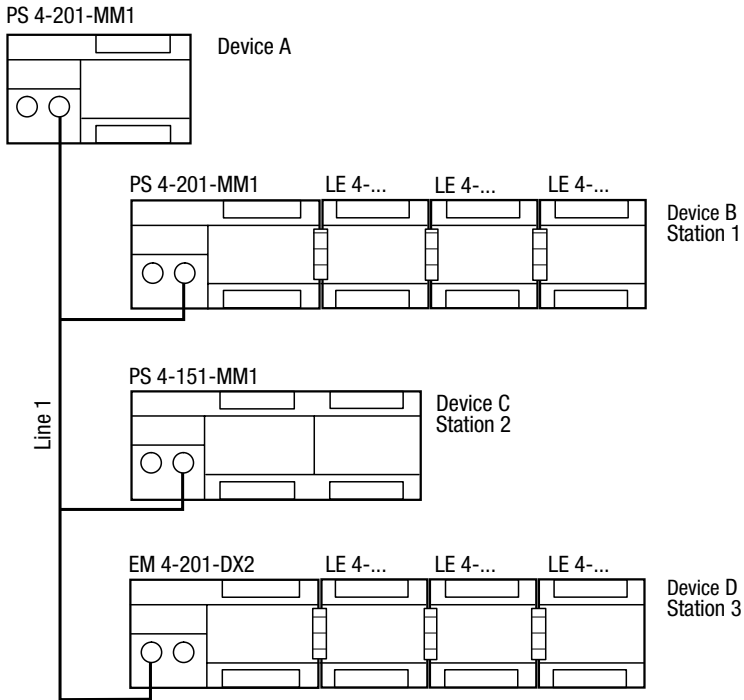

Figure 19: Configuration example

Master: Device A
Intelligent slaves: Devices B and C
Slave for expanding the remote I/O: D

The stations shown in the configuration example are configured as follows:

Configuration of device A

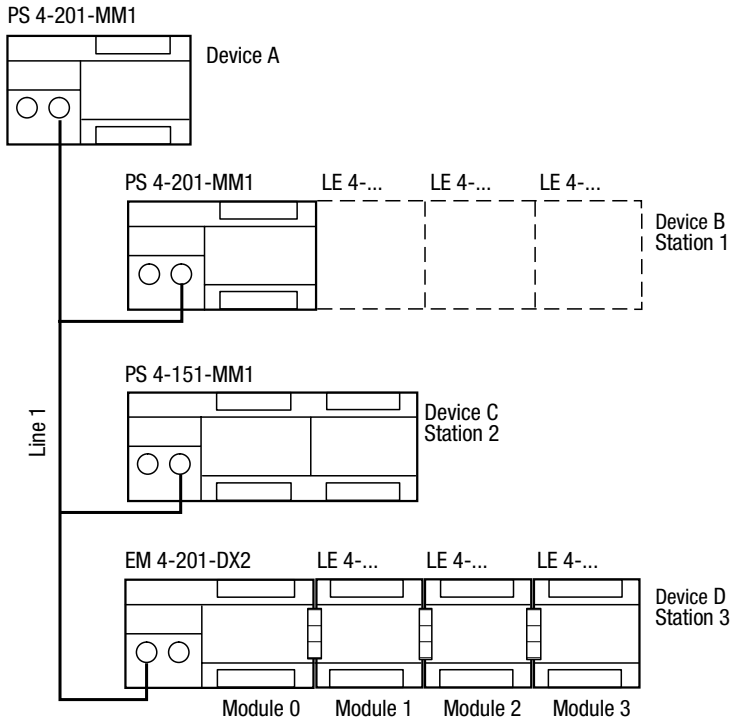

Figure 20: Configuration of device A

Table 6: Configuration of device A

Device	Type	Line	Station	Module	Parameter
A	PS4-201-MM1	0	0	0	Bus status: master Baud rate: 375 kBaud CRC status for slaves 1 to 3: OFF
B	PS4-201-MM1	1	1	0	Input data: 20 Output data: 10
C	PS4-151-MM1	1	2	0	Input data: 40 Output data: 38
D	EM4-201-DX2	1	3	0	-
	1st LE4	1	3	1	
	2nd LE4	1	3	2	
	3rd LE4	1	3	3	

Configuration of device B

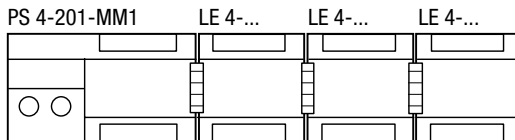

Figure 21: Configuration of device B

Table 7: Configuration of device B

Device	Type	Line	Station	Module	Parameter
B	PS4-201-MM1	0	0	0	Bus status: slave Slave address: 2 Input data: 10 Output data: 20 Remote control: OFF
	1st LE4	0	0	1	-
	2nd LE4	0	0	2	
	3rd LE4	0	0	3	

Configuration of device C

PS 4-151-MM1

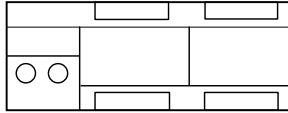

Figure 22: Configuration of device C

Table 8: Configuration of device C

Device	Type	Line	Station	Module	Parameter
C	PS4-151-MM1	0	0	0	Bus status: slave Slave address: 3 Input data: 38 Output data: 40 Remote control: OFF

5 Slave Addressing

Slaves for expanding remote inputs/outputs

The PS4-200 master PLC and the slaves for expanding the remote inputs/outputs can communicate with one another using the Sucone tK or K1 protocols. The protocol is selected by the master automatically according to the capabilities of the slaves. It is not necessary to parameterize the send or receive data length in the Topology Configurator. Suconet K/K1 selects the appropriate telegram length and automatically addresses the relevant data ranges in your application.

You can thus access remote input/output operands just as easily as local operands.

Table 9: Operand addressing of slaves for expanding remote inputs/outputs

Communication data					
Operands	Line	Station	Module	Word/byte	Bit
I/Q	0, 1 (0 = master)	1 to 8 (0 = master)	0 to 6	0, 1, 2, ... (byte)	0 to 7
IB/QB IAB/ QAB ICB				0, 2, 4, ... (word)	–
IW/QW IAW/ QAW/ ICW					
Status/diagnostics					
IS	0, 1 (0 = master)	1 to 8 (0 = master)	0 to 6	0, 1, 2, ... (byte)	0 to 7
ISB					



The RD/SD syntax must be used for certain types of slave for expanding the inputs/outputs instead of the I/Q syntax described here. Please refer to the table in the Appendix for the correct addressing for each station type.

The general syntax rule is as follows:

Operand-data type-line-station-module-byte-bit

Example

You wish to scan the inputs of slaves 1 and 2 marked in the diagram below.

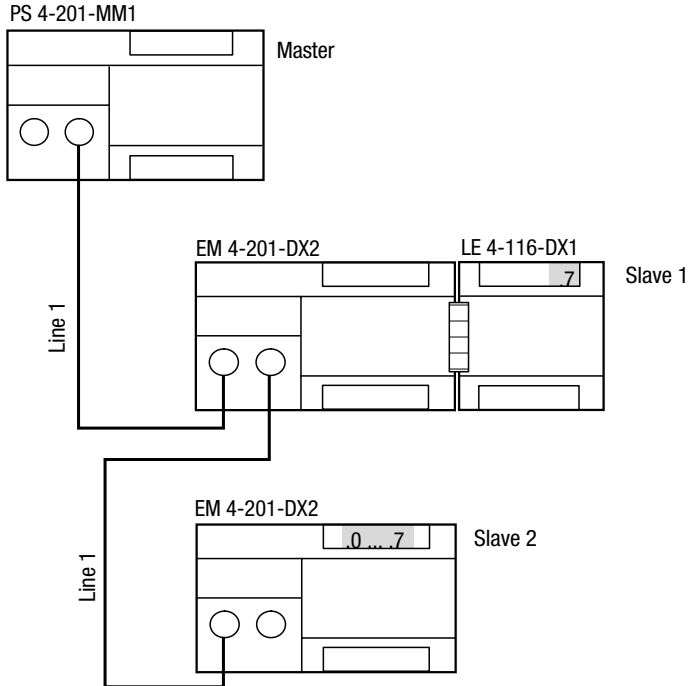

Figure 23: Configuration example for scanning the inputs of remote slaves

You can derive the syntax for scanning the inputs from the configuration:

Table 10: Syntax for addressing slaves for expanding remote inputs/outputs

IL program in ...	Data flow	Operand	Data type	Line	Station	Module	Byte/word	Bits	S 40 syntax
Master	Master ↑ Slave 1	I	Bit	1	1	1	0	7	LD %I1.1.1.0.7
	Master ↑ Slave 2	IB	Byte	1	2	0	0	–	LD%IB1.2.0.0

Intelligent slaves

When the master and an intelligent slave communicate with one another, the application determines which data is exchanged. You cannot access the input/output operands directly. You must therefore address the communication data using the RD/SD syntax.

The table below shows the operands which are available when the PS4-200 master PLC is operated with intelligent slaves.

Table 11: Operand addressing of intelligent slaves

Communication data					
Operands	Line	Station	Module	Word/byte	Bit
RD/SD	0, 1 (0 = master)	1 to 8 (0 = master)	0 to 6	0, 1, 2, ... (byte)	0 to 7
RDB/SDB				0, 2, 4, ... (word)	–
RDW/SDW					
Status/diagnostic					
IS	0, 1 (0 = master)	1 to 8 (0 = master)	0 to 6	0, 1, 2, ... (byte)	0 to 7
ISB					

RD = Receive Data; defined receive data
SD = Send Data; defined send data

The general syntax rule is as follows:

Operand-data type-line-station-module-byte-bit



If the PS4-200 is run as slave, it provides status bytes %ISB0.0.0.0 for device status information and %ISB0.0.0.1 for slave status information. These status bytes cannot be scanned together in one word but must be addressed separately.

Example

The PS4-200 (master) exchanges word data with an intelligent slave. You can define the number of send and receive bytes when you set the station parameters in the SucoSoft S 40 Topology Configurator (see chapter 4, “Software Configuration”).

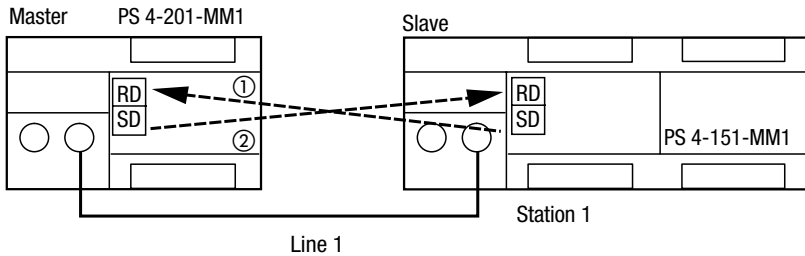

Figure 24: Configuration example for sending and receiving communication data to/from an intelligent slave

Intelligent slaves

You can derive the syntax for sending and receiving the data from the configuration.

Table 12: Syntax for addressing intelligent slaves (data type: word)

IL program in ...	Data flow	Operand	Data type	Line	Station	Module	Byte/word	Bit	Syntax
Master	Master ← Slave Master → Slave	RDW/ SDW	Word	1	1	0	0	–	RDW1.1.0.0/ SDW1.1.0.0
Slave	Slave ← Master Slave → Master	RDW/ SDW	Word	0	0	0	0	–	RDW0.0.0.0/ SDW0.0.0.0

6 Operation

Power-up behaviour

After the power supply is switched on, the PS4-200 carries out its own system test. The PLC then switches to the “Ready” or “Run” status if no hardware errors have been found.

The system test consists of the following routines:

- Memory test

- User program test

The results of the test are indicated by the “Ready”, “Run” and “Not Ready” LEDs. If the test is successful, these LEDs light up briefly when the power supply is switched on; if not, they blink.

The PLC's status depends on how the operating mode selector switch is set (see Table 13).

Shut-down behaviour

The power supply unit of the PLC detects when the power supply is switched off. Voltage dips of ≤ 10 ms can be bridged by the power supply unit. If a longer voltage dip occurs, the internal 5 V supply remains stable for at least a further 5 ms. This time is used by the microcontroller to save all the data required for a restart in the memory ranges provided for this purpose.

Operating states of the PLC

The PLC can have the following operating states: “Run”, “Ready”, “Not Ready”.



Communication with the PC is possible in all three operating states. Accordingly, the current status of the PLC and the real-time clock can always be read, for example.

Ready

The “Ready” status means the following:

- There is a user program loaded in the PLC;
- The user program is not running;
- The outputs are reset and disabled.

The PLC is switched to the “Ready” status:

- If the “Reset” button is pressed when the operating mode selector switch is set to “Halt”;
- After the power supply is switched on if the operating mode selector switch is set to “Halt”;
- By means of the programming software on the PC;

In slave mode, if the master switches to the “Halt” (stop) status and you have set in the slave parameters the “remote control” function to ON in the Sucusoft Topology Configurator (see AWB2700-1305GB, chapter 5);

If the tab of the memory module is pulled out.

Run

“Run” status means that the user program is running cyclically.

The PLC is switched to the “Run” status:

If the “Reset” button is pressed when the operating mode selector switch is set to “Run” or “Run M-Reset”;

After the power supply is switched on if the operating mode selector switch is set to “Run” or “Run M-Reset”;

By means of the programming software on the PC.

Not Ready

The user program does not run in “Not Ready” status.

The PLC is switched to the “Not Ready” status:

If there is no program loaded in the PLC;

As a result of a hardware error;

As a result of a serious error in the user program (e.g. cycle time violation)

Once the error has been rectified, you can cancel the “Not Ready” status as follows:

By pressing the “Reset” button; if the operating mode selector switch is set to “Run M-Reset”, the PLC will be switched to the “Run” status;

By switching the power supply off and then on again; if the operating mode selector switch is set to “Run M-Reset” the PLC will be switched to the “Run” status;

By means of the programming software on the PC.

Overview

Table 13: Overview of the operating states

Position of operating mode selector switch	PLC status before action	Action		PLC status after action (DSW = diagnostic status word)
		Press Reset button	Power supply off/on	
1 (Halt)	Run	×	–	Ready
	Ready	×	–	Ready; DSW acknowledged ¹⁾
	Not Ready	×	–	Ready; DSW acknowledged ¹⁾
	Run	–	×	Ready after remaining cycle processed ¹⁾
	Ready	–	×	Ready ¹⁾
	Not Ready	–	×	Not Ready
		–	–	DSW (diagnostic)
		–	–	DSW (error)
2 (Run)	Run	×	–	DSW acknowledged
	Ready	×	–	Run (depends on system parameter setup) ^{1) 2)}
	Not Ready	×	–	Via “Ready” to “Run” (depends on setup) ¹⁾
	Run	–	×	Run (with start condition) ¹⁾ , after remaining cycle processed
	Ready	–	×	Run (depends on system parameter setup) ^{1) 2)}
	Not Ready	–	×	Via “Ready” to “Run” (acc. to system parameter setup) ¹⁾
3 (Run M-Reset)	Run	×	–	DSW acknowledged
	Ready	×	–	Run (cold start) ¹⁾
	Not Ready	×	–	Run (cold start) ¹⁾
	Run	–	×	Run (cold start) ¹⁾
	Ready	–	×	Run (cold start) ¹⁾
	Not Ready	–	×	Run (cold start) ¹⁾

Legend for Table 13:

- 1) If the programs in the memory module and the RAM of the PLC are not the same, the program in the memory module (backup program) will be copied to the RAM.
- 2) After the user program has been transferred to the PLC or after the memory module has been booted, the PLC is switched to “Not Ready” if the start condition in the system parameter setup has been set to “Halt” (stop), i.e. a cold start is required.

Whenever the PLC is started by switching on the power supply, by pressing the “Reset” button or by means of the PC, the backup program is compared with the program in the RAM. If the programs are not the same, the program in the memory module (backup program) is copied to the RAM.

If the user program in the memory module is defective, it is updated, providing the user program in the RAM is valid. An update is also carried out every time the user program is transferred from the PC to the PLC.

Start-up behaviour

The PLC can be either cold-started or warm-started.

Cold start

A cold start causes all the data fields (marker ranges, inputs/outputs, module parameters) to be reset. The user program is executed from the beginning.

A cold start can be initiated as follows:

By pressing the “Reset” button if the operating mode selector switch is set to “Run M-Reset”, providing the PLC is currently in the “Ready” or “Not Ready” status;

By switching on the power supply if the operating mode selector switch is set to “Run M-Reset”;

By means of the programming software on the PC provided that the PLC is currently in the “Ready” or “Not Ready” status.



A cold start can also be initiated via the system parameters if the operating mode selector switch is set to “Run”. For this activate the Cold Start option in Behaviour after Not Ready in the Parameters dialog.

A cold start is always necessary after a new user program has been transferred to the PLC.

Warm start

A warm start causes the user program to be continued from the point at which it was interrupted to the end of the cycle. The outputs and the communication data are set to “0” for the remainder of this cycle. The PLC is then initialized and the program is executed cyclically. Retentive data fields remain stored.

The setting of retentive marker ranges is described in the manual “Sucosoft S 40 User Interface” (AWB2700-1305GB, chapter 7).

A warm start can be initiated as follows:

By pressing the “Reset” button if the operating mode selector switch is set to “Run”, providing the PLC is currently in the “Ready” status;

By switching on the power supply if the operating mode selector switch is set to “Run”, providing the PLC contains a battery in working condition;

By means of the programming software on the PC, providing the PLC is currently in the “Ready” status.



A warm start can also be initiated via the system parameters if the operating mode selector switch is set to “Run”. For this activate the Warm Start option in Behaviour after Not Ready in the Parameters dialog.



Warning!

If you initiate a warm start via the system parameters, your data may lose its consistency.

Program transfer

If the user program does not contain any syntax errors, the compiler in the programming device (PC) translates it into a code that can be understood and executed by the CPU. You must then load the user program into the RAM of the CPU using the “Transfer” menu. The microprocessor executes the program there in the “Run” status.

PC → PLC

When a program is transferred from the PC to the PLC, the PS4-200 must be in the “Ready” or “Not Ready” status. The setting of the operation mode selector switch on the operator console is not important.

- ▶ Transfer the program to the PLC; refer to the manual “Sucosoft S 40 User Interface” (AWB2700-1305GB, chapter 8).



Please refer to the section “Programming through Suconet K” for details of how to transfer the user program to the PLC through Suconet K.

If the operating mode selector switch is set to “Halt” (stop), the LEDs for “Ready” and “Not Ready” will light up while the program is being transferred together with the LED for input I 0.0. They confirm that the data transfer between the PS4-200 and the PC is progressing successfully.

PC → PLC and memory module

- ▶ Plug the memory module into the PLC (the PLC must be switched off).
- ▶ Switch on the PLC. The PLC must be switched to the “Ready” or “Not Ready” status.
- ▶ Transfer the program from the PC to the PLC. The program is now loaded into both the PLC and the memory module.

Starting the PLC with a program stored in the memory module

Starting the PLC with a program stored in the memory module

The procedure for starting a user program in the memory module is as follows:

- ▶ Plug the memory module into the PLC (the PLC must be switched off). The setting of the operate mode selector switch is not important.
- ▶ Switch on the PLC. The program in the memory module is then copied to the PS4-200 and the PLC is started up according to the configured startup conditions.

Programming via Suconet K

It is possible to program several networked stations and to run test and startup functions from a single programming device attached to Sucone tK without having to connect a programming cable to each of the stations in turn. This method can be used for all stations which are connected to the line served directly by the master PLC. If one of these stations (e.g. LE4-501-BS1) opens another line, you will not be able to access the stations connected to it (see broken line in figure below). For further information on this topic refer to the manual "Sucosoft S 40 User Interface" (AWB2700-1305GB, chapter 8).

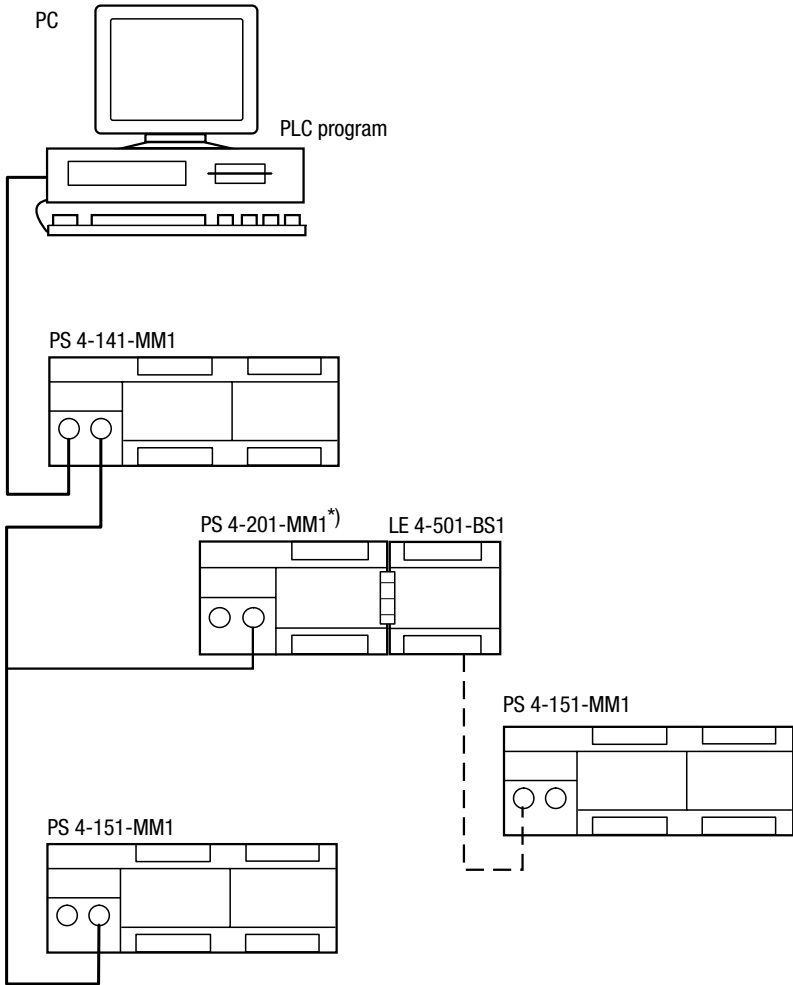

Figure 25: Programming via Suconet K

*) Programming on the PS4-201-MM1 is possible with Version 05 or higher.

7 Testing/Commissioning/Diagnostics

Status LEDs

The coloured light-emitting diodes (LEDs) allow fast and simple diagnostics of the PLC functions. The states of the inputs/outputs are easy to monitor.

Table 14: Significance of the LEDs

LED	Status	Significance
Ready	Off	–
	On (yellow)	Self-test successfully completed and CPU ready to start
	Blinking (3 seconds)	Suconet K error
Run	Off	Program in “Halt” (stop) status
	On (yellow)	User program is running
Not Ready	Off	No errors in CPU and user program
	On (red)	No user program or user program incorrect CPU error Serious error in user program
Battery	Off	Battery in good condition
	On (red)	Battery fault ¹⁾
Status of Inputs	Off	Input not activated
	On (green)	Input activated
Status of outputs	Off	Output not activated
	On (green)	Output activated



1) Caution!

Data may be lost if the battery does not supply sufficient power. Always replace the battery with the power supply switched on!

Diagnostics

Status information is scanned hierarchically using the diagnostics status word and the station's diagnostics byte as well as the diagnostics bytes of any local expansion modules which are connected to it.

Diagnostics status word

The diagnostics status word provides an overview of the various error messages. It consists of 16 bits. The diagnostics bits are subdivided into two categories:

Category D (diagnostics): bits 0 - 7

Category E (error): bits 8 - 15

The diagnostics bits in category D have an indication function. They can become set while the PLC is still in the "Run" or "Ready" status.

The diagnostics bits in category E cause the PLC to be switched to the "Not Ready" status.

The diagnostics bits are displayed in the System Diagnostics window of Sucosoft S 40 (see manual "Sucosoft S 40" User Interface AWB2700-1305GB, chapter 8).

The diagnostics bits can also be displayed on the controller's input LEDs. For this proceed as follows:

- ▶ Set the operating mode selector switch to "Halt" and refer to the following tables to interpret the controller's operating state. Press the "Reset" button if you want to acknowledge the error signals.

Table 15: Diagnostics bit display

LED	PLC status Run/ Ready	PLC status Not Ready
.0	–	–
.1	DDS	ENR
.2	DDK	ERT
.3	DLS	EDR
.4	DLK	EPM
.5	DMC	EWD
.6	DBM	EDC
.7	DAC	ECT

Table 16: Description of diagnostic (indication) bits (Run/ Ready status)

Code	Message name	Diagnostics message description
DDS	Diagnostic Remote Status	Error in the status of a remote expansion device. The basic unit's Suconet K interface has encountered a network error with one of the stations. The error can be localized by inspecting the diagnostics byte for each of the stations.
DDK	Diagnostics Remote Configuration	Error in the configuration of the remote expansion devices. Possible causes: <ul style="list-style-type: none"> – Less Suconet stations than the number defined in the Topology Configurator – Suconet station not responding – Data transfer error
DLS	Diagnostics Local Status	Error in status of local expansion device.
DLK	Diagnostics Local Configuration	Error in the configuration of the local expansion devices.
DMC	Diagnostics Memory Card	Backup not present; the memory module is not present or faulty. "DMC" also appears if the ZB4-032-SR1 memory module is used.
DBM	Diagnostics Battery Module	Battery monitoring: the battery voltage is too low. Change the battery.
DAC	Diagnostics Power Failure	Power supply failure.

Table 17: Description of diagnostic (error) bits (Not Ready status)

Code	Message name	Diagnostics message description
ENR	Restart only with M-Reset (retentive marker reset).	This error appears if you have selected the option “Halt” under “Start after Not Ready” in the PS4-200 configuration and have tried to carry out a warm start after a category E error has occurred. You need to carry out a cold start (M-Reset).
ERT	Error Run Time	The PLC has encountered a runtime error.
EDR	Error Data Retention	The data retention is corrupted in the operating system.
EPM	Error Program Module	Error in program memory; error found via checksum for user program.
EWD	Error Watch Dog	CPU failure; the CPU hardware watchdog has indicated a failure.
EDC	Error DC	DC supply failure in base module (module 0)
ECT	Error Cycle Time	Cycle time exceeded; the max. cycle time set in the program was exceeded.

Diagnostics byte for Suconet K stations

In order to get more details about the information contained in the diagnostics status word, you can scan the diagnostics byte of each of the stations and of any local expansion modules that are connected to them. You only have read access to this information.

Each station and each local expansion module on the Suconet K line has its own status information. The diagnostics information available is dependent on the respective type of Suconet station or local expansion module.



There is a group message containing status information for every station on the Suconet K line. This information applies to the respective CPU and to any local expansion modules (LE) which are connected to it.

Message byte

The status information indicates, for example, whether:

- The device ID is incorrect

- The device has been disconnected from the Suconet bus or does not respond

- There is a short-circuit at the digital output of the station, etc.

The status information and its meaning are described in the manuals for the respective Suconet stations and local expansion modules.

Message byte

The message byte contains information about the status of the PLC, image data relating to the network stations, the PLC's startup behaviour, etc. You only have read access to this information.

For further information on message byte, refer to the "PLC_Message" function block description in the manual "Language elements for the PS4-150/-200/-300 and PS416" (AWB2700-1306GB).

Appendix

Optimizing the exchange of send and receive data

The 128 byte communication buffer (COB) of the PS4-200 master is used to alternately send and receive data to and from each of the stations in turn.

After the master has sent the data (send data) to a station, this now free area of the COB memory plus any unused COB memory is available to receive data (receive data) from the slave. As long as there is sufficient free memory available in the COB each time the master receives data from a slave in this way, the 128 byte COB can be used alternately for 128 bytes of send data and 128 bytes of receive data.

If there is not sufficient free memory when the master receives data from a slave, valid data in the COB may be overwritten and the PS4-201-MM1 may switch to the “Not Ready” status (error messages “ERT” and “EPM”) after transferring the program.

The reason for this behaviour and its remedy is illustrated in the following examples.

Example

A PS4-201-MM1 (master) needs to exchange data with three slaves A, B, C (also PS4-201-MM1) as shown in the following figure. The number of bytes received from each slave also includes the diagnostics bytes from the slave and from any local expansion modules which are connected to it.

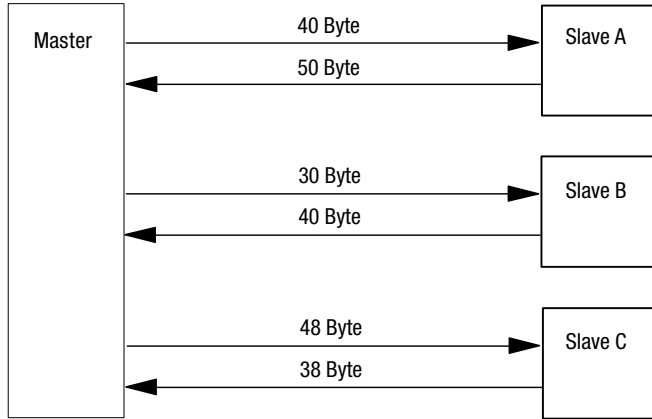

Figure 26: Data exchange between master and slaves

Incorrect station address assignment

- Slave A: station 1
- Slave B: station 2
- Slave C: station 3

The subdivision of the communication buffer (COB) in the master is then as follows:

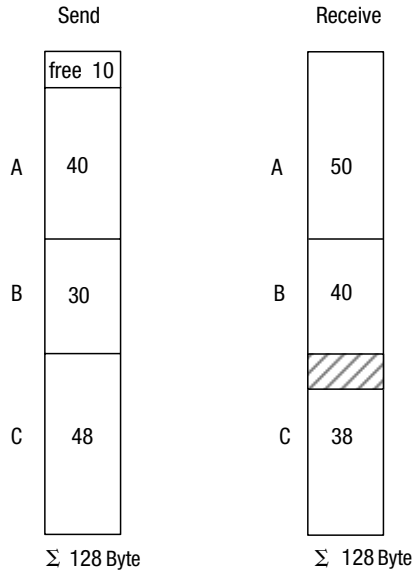

Figure 27: Subdivision of the COB with incorrect station address assignment

Sequence of communication:

1. Master sends 40 bytes to slave A:
Free COB memory at this stage = 50 bytes
2. Master receives 50 bytes from slave A:
Free COB memory at this stage = 0 bytes
3. Master sends 30 bytes to slave B:
Free COB memory at this stage = 30 bytes
4. Master receives 40 bytes from slave B:
Overlapping of 10 bytes between send and receive data. The controller goes to the “Not Ready” state.



The Sucsosoft S 40 software automatically checks the configuration and warns about possible overlapping.

Correct station address assignment:

The required amount of data can be sent and received successfully by assigning different slave addresses with the topology configurator as follows:

- Slave A: station 3
- Slave B: station 2
- Slave C: station 1

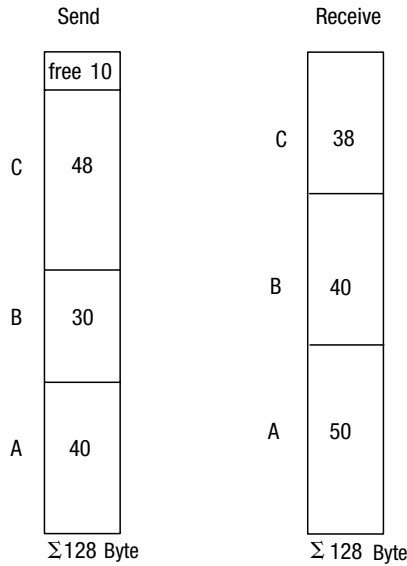

Figure 28: Subdivision of the COB with functionally correct station address assignment

No overlapping takes place in this case. After polling the first station, the master has sent 48 bytes but only received 38 bytes. Including the unused 10 bytes, a total of 20 bytes of memory are now available. This is used by the second and third polling process, where the master receives 10 bytes more from both stations 2 and 3 (40/50 bytes) than it sends (30/40 bytes).

Accessories

Designation	Type	Description/application
Programming cable	ZB4-303-KB1	Adapter for programming the PS4-200 with a PC
Memory module	ZB4-160-SM1	32 Kbyte RAM module for expanding the user program memory and 128 Kbyte flash EPROM
Memory module	ZB4-032-SR1	32 Kbyte RAM module for expanding the user program memory
Memory module	ZB4-128-SF1	128 Kbyte flash EPROM
Plug-in screw terminal	ZB4-110-KL1	Plug-in screw terminal for the input/output level
Twin-level terminal block	ZB4-122-ML1	Twin-level terminal block for distributing potential, e.g. for connecting 3-pole proximity switches to a PLC or a local expansion module
Hinged cover	ZB4-101-GZ1	Hinged cover with space for labelling inputs/outputs (PS4, EM4, LE4)
Feet	ZB4-101-GF1	Feet for screwing the PS4 onto a mounting plate
Backup battery	ZB4-600-BT1	Battery for backing up the RAM of the PS4-200
Simulator	ZB4-108-ES1	Simulator for digital inputs
Data cable	KPG 1-PS3	Cable between the PS4-200 and a slave; length: 0.5 m
T connector	TBA 3.1	For connecting a station to the Suconet K/K1 line
Data plug connector	S1-PS3	5-pole DIN plug connector for the RS 485 interface of the PS4-200-MM1
Cable	LT 309.096	Cable, $2 \times 0.5 \text{ mm}^2$, screened and twisted for making your own Suconet K cable
Screen grounding kit	ZB4-102-KS1	Screen grounding kit for Suconet incl. screen grounding clips
Snap fastener for the top-hat rail	FM4/TS35	Weidmüller, Order no. 068790
Terminal clip for snap fastening	KL Bü3-8SC	Weidmüller, Order no. 169226

Slave addressing Receive data

Slave	Byte 1	Byte 2	Byte 3	...	Last byte	Data type
EM4-111-DR1	IBx.y.0.0					Bit, byte
EM4-101-DD1/88	IBx.y.0.0					Bit, byte
EM4-101-DD1/106	IBx.y.0.0	IBx.y.0.1				Bit, byte
EM4-101-AA1 V 01	IABx.y.0.0	IABx.y.0.1	IABx.y.0.2	...	IABx.y.0.5	Byte
EM4-101-AA1 V 02						
AA1B64 (8 Bit/SBI)	IABx.y.0.0	IABx.y.0.1	IABx.y.0.2	...	IABx.y.0.5	Byte
AA1W33 (12 Bit/SBI)	IAWx.y.0.0		IAWx.y.0.2		IAWx.y.0.4	Word
EM4-101-AA2						
AA2B84	IABx.y.0.0	IABx.y.0.1	IABx.y.0.2	...	IABx.y.0.7	Byte
AA2W84	IAWx.y.0.0		IAWx.y.0.2	...	IAWx.y.0.14	Word
EM4-201-DX1	IBx.y.0.0	IBx.y.0.1				Bit, byte
EM4-201-DX2	IBx.y.0.0	IBx.y.0.1				Bit, byte, word
PS4-1x1, passive	IBx.y.0.0	–	IABx.y.0.0		IABx.y.0.1	(Bit), Byte
PS4-1x1, active	RDBx.y.0.0	RDBx.y.0.1	RDBx.y.0.2	...	RDBx.y.0.6	Bit, byte
PS4-141-MM1	RDBx.y.0.0	RDBx.y.0.1	RDBx.y.0.2	RDBx.y.0.77	Bit, byte, word
PS4-151-MM1	RDBx.y.0.0	RDBx.y.0.1	RDBx.y.0.2	...	RDBx.y.0.77	Bit, byte, word
PS4-201-MM1	RDBx.y.0.0	RDBx.y.0.1	RDBx.y.0.2	...	RDBx.y.0.77	Bit, byte, word
PS4-401-MM1	RDBx.y.0.0	RDBx.y.0.1	RDBx.y.0.2	...	RDBx.y.0.6	Byte, word
PS4-401-MM2	RDBx.y.0.0	RDBx.y.0.1	RDBx.y.0.2	...	RDBx.y.0.83	Bit, byte, word
PS316 (SBI)/306	RDBx.y.0.0	RDBx.y.0.1	RDBx.y.0.2	RDBx.y.0.6	Bit, byte, word
EPC335	RDBx.y.0.0	RDBx.y.0.1	RDBx.y.0.2	...	RDBx.y.0.6	Bit, byte, word
PS3-DC	IBx.y.0.0	IBx.y.0.1	IABx.y.0.0	...	IABx.y.0.3	(Bit), Byte
PS3-AC	IBx.y.0.0	IBx.y.0.1	IABx.y.0.0	...	IABx.y.0.3	(Bit), Byte
PS3-8	IBx.y.0.0	IBx.y.0.1				Bit, byte
LE4-501-BS1	RDBx.y.0.0	RDBx.y.0.1	RDBx.y.0.2	...	RDBx.y.0.77	Bit, byte, word
CM-501-FS1	IBx.y.0.0	RDBx.y.0.1	RDBx.y.0.1	...	RDBx.y.0.5	Bit, byte

Slave addressing

Slave	Byte 1	Byte 2	Byte 3	...	Last byte	Data type
SBI-AMD3	RDBx.y.0.0	RDBxBx.y.0.1	RDBx.y.0.2	...	RDBx.y.0.6	Byte, word
SBI-AMX	RDBx.y.0.0	RDBx.y.0.1	RDBx.y.0.2	...	RDBx.y.0.6	Byte, word
SIS Type 80D0 to	RDBx.y.0.0	RDBx.y.0.1	RDBx.y.0.2	RDBx.y.0.6	Bit, byte, word
SIS Type 80EF	RDBx.y.0.0	RDBx.y.0.1	RDBx.y.0.2	...	RDBx.y.0.6	Bit, byte, word
A4-220.1	RDBx.y.0.0	RDBx.y.0.1				Byte, word
A5-220.1	RDBx.y.0.0	RDBx.y.0.1	RDBx.y.0.2	...	RDBx.y.0.6	Byte, word
VTP0-H-Tx	RDBx.y.0.0	RDBx.y.0.1	RDBx.y.0.2	...	RDBx.y.0.6	Byte, word
VTP1/2-H-T6	RDBx.y.0.0	RDBx.y.0.1	RDBx.y.0.2	RDBx.y.0.17	Byte, word
ZB4-501-UM2	RDBx.y.0.0	RDBx.y.0.1	RDBx.y.0.2	...	RDBx.y.0.23	Bit, byte, word
RMQ16I	IBx.y.0.0	IBx.y.0.1				Bit, byte
RBI1.1	RDBx.y.0.0	RDBx.y.0.1	RDBx.y.0.2	RDBx.y.0.6	Bit, byte

x = line, y = station

Send data

Slave	Byte 1	Byte 2	Byte 3	...	Last byte	Data type
EM4-111-DR1	QBx.y.0.0					Bit, byte
EM4-101-DD1/88	QBx.y.0.0					Bit, byte
EM101-DD1/106	QBx.y.0.0	QBx.y.0.1				Bit, byte
EM4-101-AA1 V 01	QABx.y.0.0	QABx.y.0.1	QABx.y.0.2	–	QABx.y.0.4	Byte
EM4-101-AA1 V 02						
AA1B64 (Bit/SBI)	QABx.y.0.0	QABx.y.0.1	QABx.y.0.2	–	QABx.y.0.4	Byte
AA1W33 (2 Bit/SBI)	QAWx.y.0.0		QAWx.y.0.2		QAWx.y.0.4	Word
EM4-101-AA2						
AA2B84	QABx.y.0.0	QABx.y.0.1	QABx.y.0.2	–	QABx.y.0.3	Byte
AA2W84	QAWx.y.0.0		QAWx.y.0.2	...	QAWx.y.0.6	Word

Appendix

Slave	Byte 1	Byte 2	Byte 3	...	Last byte	Data type
EM4-201-DX1	QBx.y.0.0	QBx.y.0.1				Bit, byte
EM4-201-DX2	QBx.y.0.0	QBx.y.0.1				Bit, byte, word
PS4-1x1, passive	QBx.y.0.0	–	–		–	(Bit,) Byte
PS4-1x1, active	SDBx.y.0.0	SDBx.y.0.1	SDBx.y.0.2	...	SDBx.y.0.5	Bit, byte
PS4-141-MM1	SDBx.y.0.0	SDBx.y.0.1	SDBx.y.0.2	...	SDBx.y.0.77	Bit, byte, word
PS4-151-MM1	SDBx.y.0.0	SDBx.y.0.1	SDBx.y.0.2	...	SDBx.y.0.77	Bit, byte, word
PS4-201-MM1	SDBx.y.0.0	SDBx.y.0.1	SDBx.y.0.2	...	SDBx.y.0.77	Bit, byte, word
PS4-401-MM1	SDBx.y.0.0	SDBx.y.0.1	SDBx.y.0.2	...	SDBx.y.0.5	Byte, word
PS4-401-MM2	SDBx.y.0.0	SDBx.y.0.1	SDBx.y.0.2	...	SDBx.y.0.83	Bit, byte, word
PS316 (SBI)/306	SDBx.y.0.0	SDBx.y.0.1	SDBx.y.0.2	...	SDBx.y.0.5	Bit, byte, word
EPC335	SDBx.y.0.0	SDBx.y.0.1	SDBx.y.0.2	...	SDBx.y.0.5	Bit, byte, word
PS3-DC	QBx.y.0.0	QBx.y.0.1	QABx.y.0.0		QABx.y.0.0	(Bit), Byte
PS3-AC	QBx.y.0.0	QBx.y.0.1	QABx.y.0.0		QABx.y.0.0	(Bit), Byte
PS3-8	QBx.y.0.0	QBx.y.0.1				Bit, byte
LE4-501-BS1	SDBx.y.0.0	SDBx.y.0.1	SDBx.y.0.2	SDBx.y.0.77	Bit, byte, word
CM-501-FS1	QBx.y.0.0	SDBx.y.0.1	SDBx.y.0.1	...	SDBx.y.0.5	Bit, byte
SBI-AMD3	SDBx.y.0.0	SDBx.y.0.1	SDBx.y.0.2	...	SDBx.y.0.5	Byte, word
SBI-AMX	SDBx.y.0.0	SDBx.y.0.1	SDBx.y.0.2	...	SDBx.y.0.5	Byte, word
SIS Type 80D0 to	SDBx.y.0.0	SDBx.y.0.1	SDBx.y.0.2	...	SDBx.y.0.5	Bit, byte, word
SIS Type 80EF	SDBx.y.0.0	RDBx.y.0.1	SDBx.y.0.2	...	SDBx.y.0.5	Bit, byte, word
A4-220.1	SDBx.y.0.0	SDBx.y.0.1				Byte, word
A5-220.1	SDBx.y.0.0	SDBx.y.0.1	SDBx.y.0.2	...	SDBx.y.0.5	Byte, word
VTP0-H-Tx	SDBx.y.0.0	SDBx.y.0.1	SDBx.y.0.2	...	SDBx.y.0.5	Byte, word
VTP1/2-H-T6	SDBx.y.0.0	SDBx.y.0.1	SDBx.y.0.2	...	SDBx.y.0.17	Byte, word
ZB4-501-UM2	SDBx.y.0.0	SDBx.y.0.1	SDBx.y.0.2	...	SDBx.y.0.23	Bit, byte, word
RMQ16I	QBx.y.0.0	QBx.y.0.1				Bit, byte
RBI1.1	SDBx.y.0.0	SDBx.y.0.1	SDBx.y.0.2	...	SDB x.y.0.5	Bit, byte

x = line, y = station

Technical Data

General	
Standards	EN 61 131-2, EN 50 178
Ambient temperature	0 to 55 °C
Storage temperature	-20 to 70 °C
Vibration resistance	1 g/0 to 150 Hz
Shock resistance	15 g/11 ms
Vibration	Constant 1 g, f = 0 up to 150 Hz
EMC	see page 83
Programming interface	RS 232, length of programming cable < 3 m
Network interface	RS 485
Bus	Suconet K
Data cable length	600 m/300 m
Transfer rate	187.5 kBit/s to 375 kBit/s
Operating mode	Master/slave
Degree of protection	IP 20
Rated insulation voltage U_i	600 V AC
Real-time clock	Yes
Accuracy of real-time clock	6.1 min./year (battery-backed)
Battery (life)	Normally 5 years
Expandable (locally)	Max. 6 LEs
Expandable (remotely)	Max. 8 stations
User and data memory (internal)	32 Kbyte
Memory modules (external)	32 Kbyte RAM or 128 Kbyte flash memory or 32 Kbyte RAM and 128 Kbyte flash memory
Normally Cycle time for 1 K instructions (bits, bytes)	5 ms
No. of inputs (local)	8
No. of outputs (local)	6
Max. no. of inputs/outputs (local)	104/102
Weight	Approx. 540 g

Power supply for CPU	
Rated voltage U_e	24 V DC
Permissible range	20.4 to 28.8 V DC
Residual ripple of input voltage	< 5%
Polarity reversal protection	Yes
Rated current I_e	Normally 250 mA + 300 mA per LE
Inrush current and duration	4 A < 5 ms
Power consumption	Approx. 6 W
Power dissipation (complete device)	Approx. 6 W
Bridging of voltage dips	
Duration of dip	10 ms
Repetition rate	1 s
Error indication	Yes (LEDs)
Protection class	1
Galvanic isolation	Yes
Terminals	Plug-in screw terminals
Conductor cross-section	
Flexible with ferrule	0.22 to 2.5 mm ²
Solid	0.22 to 2.5 mm ²
Rated insulation voltage	600 V AC
Inputs	
No. of inputs	8
Rated voltage U_e	24 V DC
For "0" signal	≤ 5 V DC (limit value type 1)
For "1" signal	≥ 15 V DC (limit value type 1)
Max. ripple	< 5 %
Rated current I_e	
For "1" signal	Normally 6 mA for 24 V DC
Max. delay time	
From "0" to "1"	max. 100 μs
From "1" to "0"	max. 100 μs

Technical Data

Galvanic isolation	Yes
Galvanic isolation between inputs	No
Input status indication	Yes (LEDs)
Terminals	Plug-in screw terminals
Conductor cross-section	
Flexible with ferrules	0.22 to 1.5 mm ²
Solid	0.22 to 2.5 mm ²
High-speed counter input	I0.0
Clock frequency	3 kHz
Pulse shape	Square
Pulse duration	50 %
Edge duration	≤ 3 %
Alarm input	I0.1
Analog inputs	
No.	2
Signal range	0 V to 10 V
Total error	Normally 0.8% of full scale
No. of conversions	1 × per cycle
Input resistance	20 kΩ
Connection type of signal transmitter	Two-wire connection to transmitter
Digital representation of input signal	10 bits (1024 increments)
Setpoint potentiometers	
No.	2
Value range	10 bits (1024 increments)
Adjustment	With screwdriver

Outputs	
No. of outputs	6
Rated voltage U_e	24 V DC
Permissible range	20.4 to 28.8 V DC
Polarity reversal protection	Yes
Max. ripple	$\leq 5\%$
Galvanic isolation	
in groups	No
Rated current I_e	
For "1" signal	0.5 A DC for 24 V DC
Lamp load	4 W without series resistor
Utilization factor	1
Relative duty factor	100 %
Parallel connection of outputs	
No. of outputs	max. 4
Total maximum current	2 A
Total minimum current	250 mA
Residual current with "0" signal	Approx. 140 μ A
Short-circuit protection	Yes, without set
Max. short-circuit release current	1.2 A over 3 ms per output
Off delay	Normally 100 μ s
Limiting of breaking voltage	
With inductive loads	Yes, -21 V (with $U_N = 24$ V DC)
Operations per hour	
With time constant $t \leq 72$ ms	4800 (G = 1) 7500 (G = 0.5)
With time constant $t \leq 15$ ms	18000 (G = 1)
Power supply	
Polarity reversal protection	Yes
Permissible range	20.4 to 28.8 V DC
Max. ripple	$\leq 5\%$

Technical Data

Output status indication	Yes (LEDs)
Terminals	Plug-in screw terminals
Conductor cross-section	
Flexible with ferrules	0.22 to 1.5 mm ²
Solid	0.22 to 2.5 mm ²
Analog output	
No.	1
Bit resolution	12 (4096 increments)
Total error	Normally 0.4% of full scale
Output variables	0 to 10 V DC/2 mA
Connection type	Two-wire connection

General specifications on electromagnetic compatibility (EMC) of automation equipment

Emission	EN 55 011/22 Class A		
Immunity to interference			
ESD	EN 61 000-4-2	Contact discharge air discharge	4 kV 8 kV
RFI	EN 61 000-4-3	AM/PM	10 V/m
Burst	EN 61 000-4-4	Supply/digital I/O Analog I/O, fieldbus	2 kV 1 kV
Surge	EN 61 000-4-5	Digital I/O, asymmetrical DC supply, asymmetrical DC supply, symmetrical AC supply, asymmetrical AC supply, symmetrical	0.5 kV 1 kV 0.5 kV 2 kV 1 kV
Line-conducted interference	ENV 50 141	AM	10 V

Index

A

Addressing	
Slaves	49, 76
Alarm input	8
Analog inputs/outputs	9
Arrangement of the control cabinet	22

B

Backup battery	13, 75
Backup memory	12
Base module (i.e. module 0)	36
Battery	
Backup	13
Baud rate	40
Bus cable	20

C

Cable	75
Cabling	28
Clock (real-time)	14
Cold start	59
Combination memory module (160 Kbyte)	12
Commissioning	65
Communication with PC	56
Configuration	38
Intelligent slaves	37
Local expansion	36
Master with remote expansions	36
Slaves for expanding remote inputs/outputs	38
Configuration example	44
Connection	
Overview	15
Connections	
Programming device	19
Suconet K field bus	20
Connector pin assignments	
Suconet K interface	20
Controls	13
Counter, high-speed	8

CRC	41
D	
Data cable	75
Data exchange	10, 11
Data integrity	41
Data plug connector	75
Data transfer	
LEDs	62
Daylight savings time	14
Device arrangement	22
Diagnostics	65, 66
Diagnostics byte for Suconet K stations	68
Diagnostics status word	66
Digital inputs	8
Status LEDs	9
Digital outputs	9
DST	14
Dynamic memory allocation	12
E	
Elements, PS 4-200	8
EMC regulations	15
Engineering instructions	15
F	
Fastening	22
Features	6
Feet	75
Flash module	12
H	
Hardware requirements for programming	5
High-speed counter	8
Hinged cover	75
I	
Input data	41
Input delay	8
Insulation monitoring	23
Intelligent slaves	35
Interface	
Programming device	11

Suconet K	10
Interference	22

L

LED	65
LED display	9
LEDs	9, 13
Status	12
Light-emitting diodes	65
Lightning protection	31
Limit values, send and receive bytes	42
Line	40
Local expansion modules	35

M

Master PLC	35
Memory	
128 Kbyte flash module	12
160 Kbyte combination module	12
32 Kbyte RAM module	11
Backup	12
Recipe data	12
Memory allocation, dynamic	12
Memory capacity	11
Memory module	11, 75
Memory test	55
Message byte for Suconet K stations	69
Module	40
Module 0 ("base module")	36
Mounting	
On feet	34
On top-hat rail	33

N

Network programming	62, 63
Networking	10
Not Ready (operating state)	57

O

Operand addresses	
Intelligent slaves	51
Slaves for expanding remote inputs/outputs	49
Operating mode selector switch	14

Operating states (PLC), overview	58
Output data	41
P	
Parameters, setting	38
PC, connections	19
Peripheral command	9
Pin assignments	
Programming device interface (PRG)	18
Suconet K interface	20
Plug-in screw terminal	75
Potential equalization	19
Power supply	
grounding arrangements	23
Power supply unit	8
Power-up behaviour	55
Program transfer	
LEDs	62
Program transfer to PLC	61
Programming cable	5, 19, 75
Programming device interface (PRG)	11
Pin assignments	18
Programming device, connections	19
Programming networks	10
Programming via	
Suconet K	63
Programming with	
PC	11
R	
RAM memory	11
RAM module	11
Rated voltage	8
Ready	56
Real-time clock	14
Receive bytes	41
Recipe data	
Memory	12
Remote control	41
Reset button	14
Resolution	9
Retention of data	60
RS 232	11

RS 485	10
Run	57

S

Screen connection to reference potential surface	16
Screen grounding kit	75
Screening	30
Send bytes	41
Setpoint potentiometers	10
Setting parameters	38
Setting the bus terminating resistors	21
Setup, PS 4-200	6
Shutdown behaviour	55
Signal range	9
Simulator	75
Slave address	41
Slave addressing	49, 76
Slaves for expanding the remote I/O	35
Software requirements for programming	5
Start-up behaviour	59
Station	40
Status LEDs	65
Digital inputs	9
Outputs	9
PLC	12
Suconet K	
Programming via	63
Suconet K connection	20
Suconet K interface	10
pin assignments	20
Summer time, winter time	14
Suppressor circuits	30
Switch S1	10
Symbols	4
Syntax rules for addressing slaves	50
System test	55

T

T connector	75
Test of memory	55
Test of user program	55
Testing	65
Time	

Summer/winter	14
Topology configuration, procedure	36
Transfer	61
Transfer of program to PLC	61
Twin-level terminal block	75
U	
Up counter	8
User program test	55
V	
Ventilation	22
W	
Warm start	60
Wiring	28